

Modbus-RTU/ASCII to Profibus-DP Protocol Converter

DPM01

User Manual

V1.0

2024.04.18

DPM01



2024-04

Copyright ©2024 Odot Automation all rights reserved

Version Information

The document has been modified as follows:

Date	Version No.	Modify Content	Author
2024-04-18	V1.0	Initial Version	

Ownership rights information

Without the permission of the copyright owner, all or part of this document shall not be republished as a paper or electronic document.

Disclaimer

This document is only intended to assist the reader in using the products, and the company shall not be responsible for any loss or error caused by the use of the information in this document. The product and text described in this document are under constant development and refinement. Odot Automation System Co., Ltd. has the right to modify this document without notifying users.

Software download

Please log on the official website: www.odotautomation.com and click on the corresponding product page to download.

目 录

1 Product Overview	3
1.1 Product Functions	3
1.2 Main technical parameters	3
2 Hardware Description	4
2.1 Product Appearance	4
2.2 Indicator Description	5
2.3 DIP Switch	5
2.4 Profibus-DP Interface	6
2.5 Terminal definition	6
2.6 External terminal resistance	7
2.7 Installation dimension	8
3 Product application topology	8
4 Testing application in Siemens Step 7	10
4.1 Modbus RTU Master Mode	10
4.2 Modbus RTU Slave Mode	27
5 Testing application in Siemens TIA V16	34
5.1 Modbus RTU Master Mode	34
5.2 Modbus RTU Slave Mode	49
5.3 Modbus ASCII Master Mode	55
5.4 Modbus ASCII Slave Mode	57
6 Test application in Beckhoff TwinCAT 2	60
7 Annex	68
7.1 Modbus-RTU Protocol Introduction	68
7.1.1 Modbus Storage Area	68
7.1.2 Modbus Function Code	69
7.2 Brief introduction of serial port network topology	74

7.2.1 RS232.....	74
7.2.2 RS422.....	76
7.2.3 RS485.....	78

FLEXYTEC.COM

1 Product Overview

1.1 Product Functions

The DPM01 gateway is a Modbus-RTU/ASCII to Profibus-DP Protocol converter. It could realize data transmission from Modbus-RTU/ASCII to Profibus-DP protocols. Any device with an RS485 interface that supports the Modbus-RTU/ASCII protocol can be interconnected with the fieldbus Profibus-DP using this product. Such as: PLC, DCS, remote IO, transducer, motor start protection device, intelligent high and low voltage electrical appliances, fuel gauge device, and intelligent field measuring equipment and instrument etc.

1.2 Main technical parameters

1. Support Modbus function codes:01/02/03/04/05/06/15/16
2. Support Profibus-DP/V0 protocol
3. DP Communication rate: 9.6Kbps~12Mbps self-adaptive
4. DP Data Zone: the input up to 244 bytes
the output is up to 244 bytes
the maximum sum of input and output is 288 bytes
5. Maximum number of DP slave slots: 42
6. Modbus master: support
7. Modbus slave: support
8. Number of Modbus sites supported: 31
9. Modbus Baud rate:1200~115200bps Optional
10. 8 data bits, N/A, Odd or Even parity checking, 1 or 2 stop bits
11. Operating Voltage:9~36 VDC, Current: Max.50mA@24V
12. Operating temperature:-40~85°C, Relative humidity:5~95% (No Condensation)
13. Storage temperature:-55~125°C

14. Mounting type:35mm DIN-Rail

15.Size: 110*27.5*110(Length*width*height, Unit: mm)

16. Ingress protection rating IP20

17.Product certifications: CE

2 Hardware Description

2.1 Product Appearance



2.2 Indicator Description

There are total 4 LED status indicators. The symbol definition and status description are shown in “Table 2.2”.

Table 2.2 LED indicator description

Symbol	Definition	Status	Description
PWR	Power supply indicator (RED)	ON	The system power supply is normal.
		OFF	The system power supply is abnormal.
DP	DP network status indicator (RED)	ON	DP bus communication error
		Flashing	
		OFF	DP bus communication normal
TX	Series port sending indicator (GREEN)	Flashing	Series port is sending data
		ON	Series port is not sending data
RX	Series port Receiving indicator (GREEN)	Flashing	Series port is sending data
		ON	Series port is not sending data

2.3 DIP Switch



As shown in the figure, the high-level DIP switch (X16) set by the Profibus-DP address is dialed to 0, the DIP switch (X1) in the lower position is dialed to 3, this means that the address of the module in the DP network is set to $0*16+3=3$, and the valid address range of Profibus-DP is 1-125.

2.4 Profibus-DP Interface

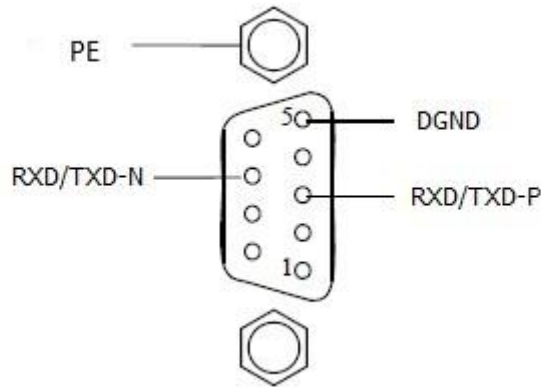

Profibus-DP port is 9 Pin terminals and its Pin definition is as follows:

Pin	RS-485	Definition	Description
1		Shield	Earthing of Shield
2		M24V	--
3	B/B'	RXD/TXD-P	Data line B
4		CNTR-P	Direction control-P
5	C/C'	DGND	Signal Grounded
6		VP(+)	+5v
7		P 24V	--
8	A/A'	RXD/TXD-N	Data line A
9		CNTR-N	Direction control-N

2.5 Terminal definition

The equipment wiring adopts 7Pin 3.81mm pitch plug-in terminal., the terminal definition of serial port as follows:

No.	Terminal	RS422 Wiring Definition	RS485 Wiring Definition	RS232 Wiring Definition
1	R-	RS422 Receiving-		
2	R+	RS422 Receiving+		
3	TB-	RS422 Sending-	RS485-	
4	TA+	RS422 Sending+	RS485+	
5	SGND	Signal GND		

6	RX			RS232 Receiving
7	TX			RS232 Sending

Power terminals are defined as follows:

No.	Symbol	Definition
1	PE	Grounding terminal
2	V-	Power Input Negative
3	V+	Power Input Positive

2.6 External terminal resistance

According to the site situation, the gateway serial port side needs an external 120 Ω terminal resistance. The RS485 bus supports a maximum of 32 nodes without relay. The "daisy chain" connection is used between nodes, and terminal resistors are required at both ends of the communication cable, and their resistance is required to be approximately equal to the characteristic impedance of the transmission cable. In short-distance transmission, no terminating resistor is required, that means no terminating resistor is generally required below 300 meters. The terminating resistor is connected to the two ends of the transmission cable.

When the gateway is used in the site, if the site RS485 bus is far away and the site interference is large, so it is necessary to add 120Ω terminal resistance at both ends of the RS485 bus to prevent the reflection of the serial signal.

Note: 120 Ω resistance attached to the package, please check.

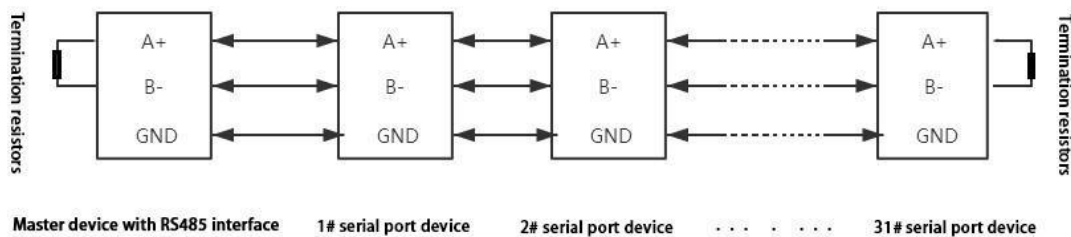

2.7 Installation dimension



3 Product application topology

The typical network topology of the RS485 interface in Modbus RTU master mode (as shown below).

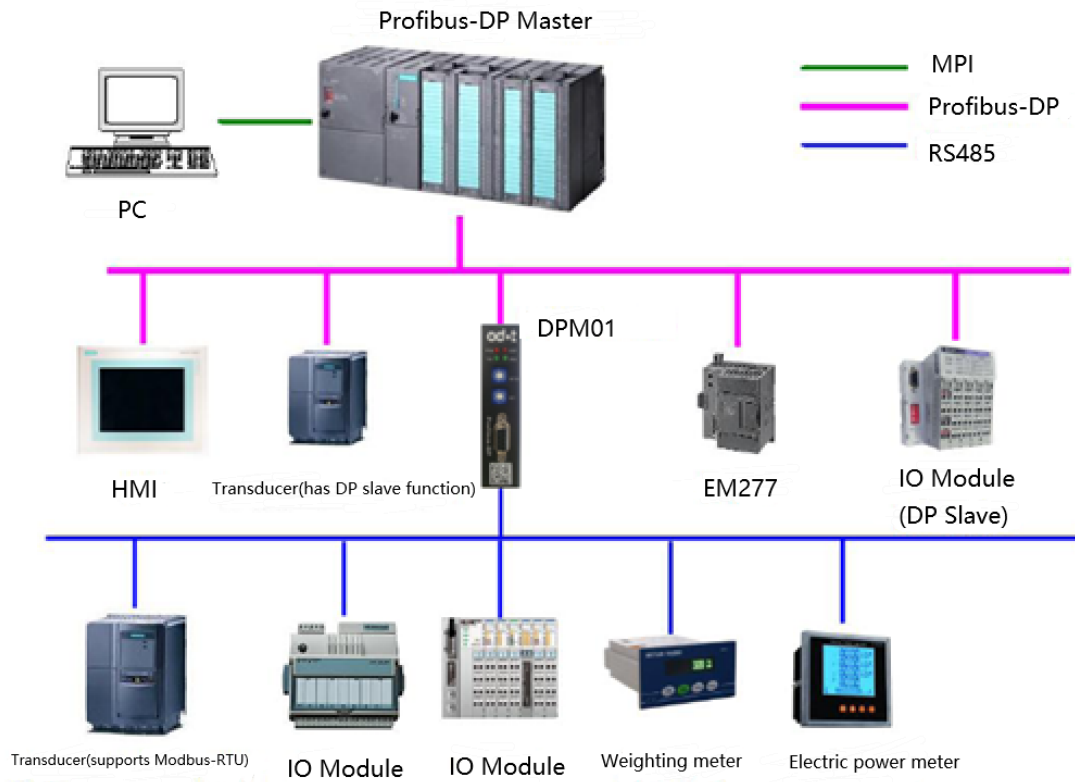

Typical network topology of RS485 interface set to Modbus RTU slave mode (as shown below)

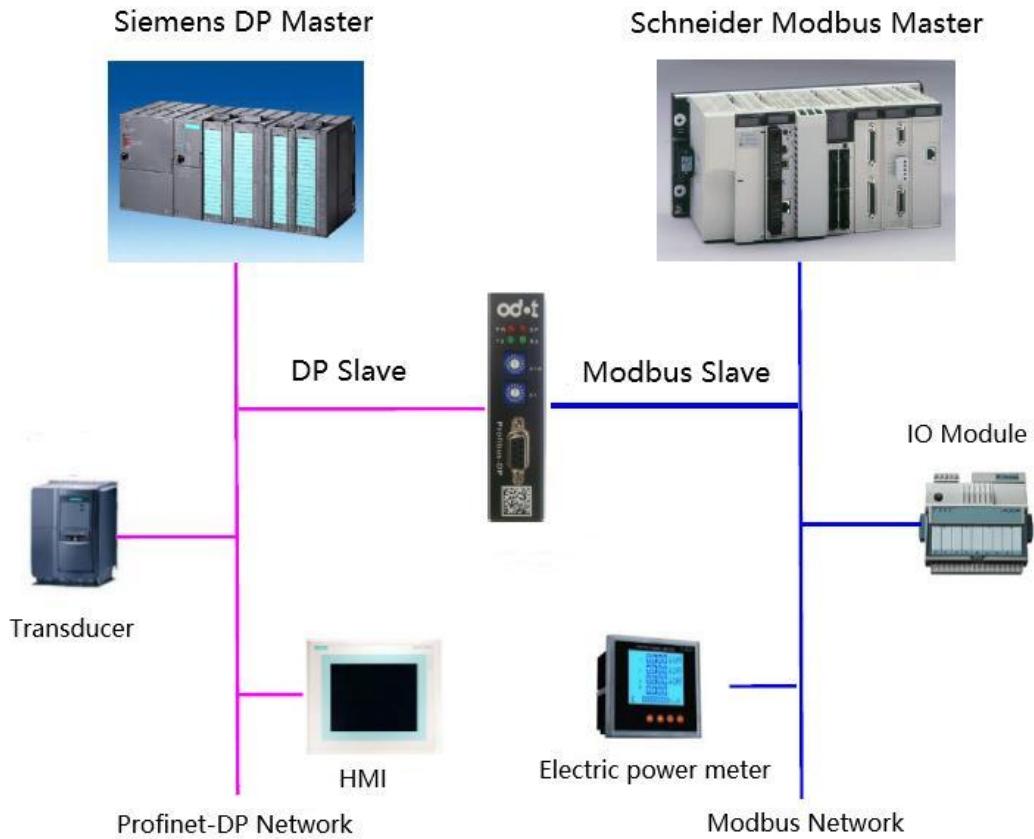

4 Testing application in Siemens Step 7

4.1 Modbus RTU Master Mode

1. Find the GSD folder in the product CD and confirm that there are the following files in the folder. If not, please contact the supplier to request them. If the following files exist, copy them to

C:\Program Files\Siemens\Step7\S7DATA\GSD



- Open Step7 software, create a new project, name DPM01-TEST. There should be no Chinese characters in the storage path

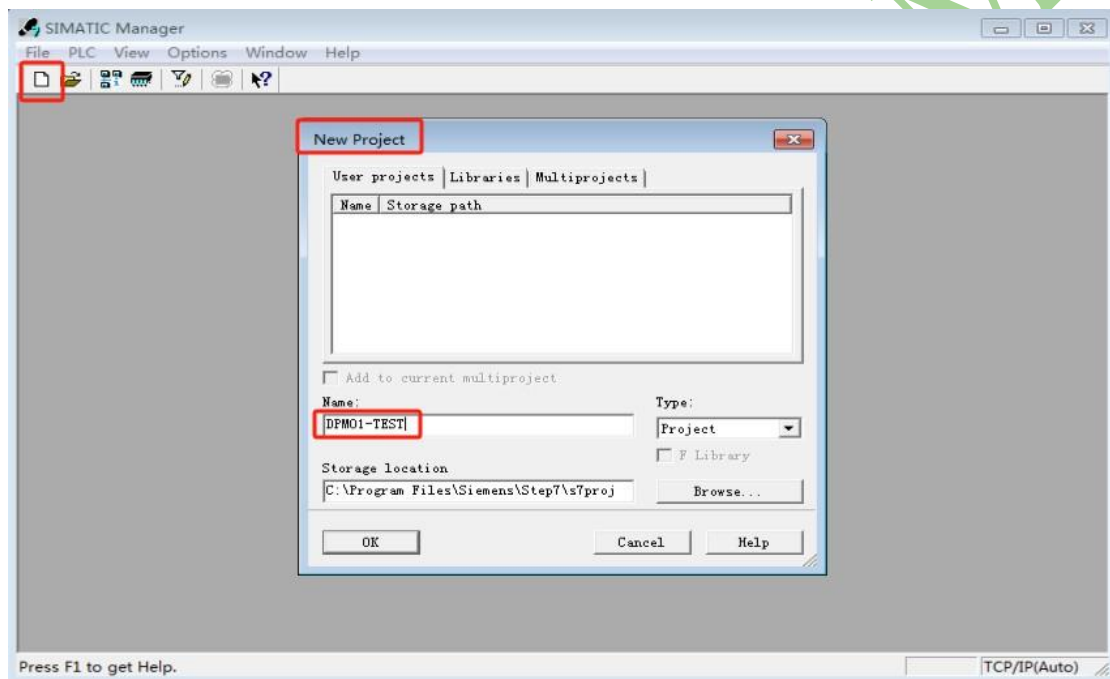

- Right click on the project name, insert a new object, select "SIMATIC 300 Site", click "SIMATIC 300", and then double-click "Hardware" on the right to enter the hardware configuration interface.

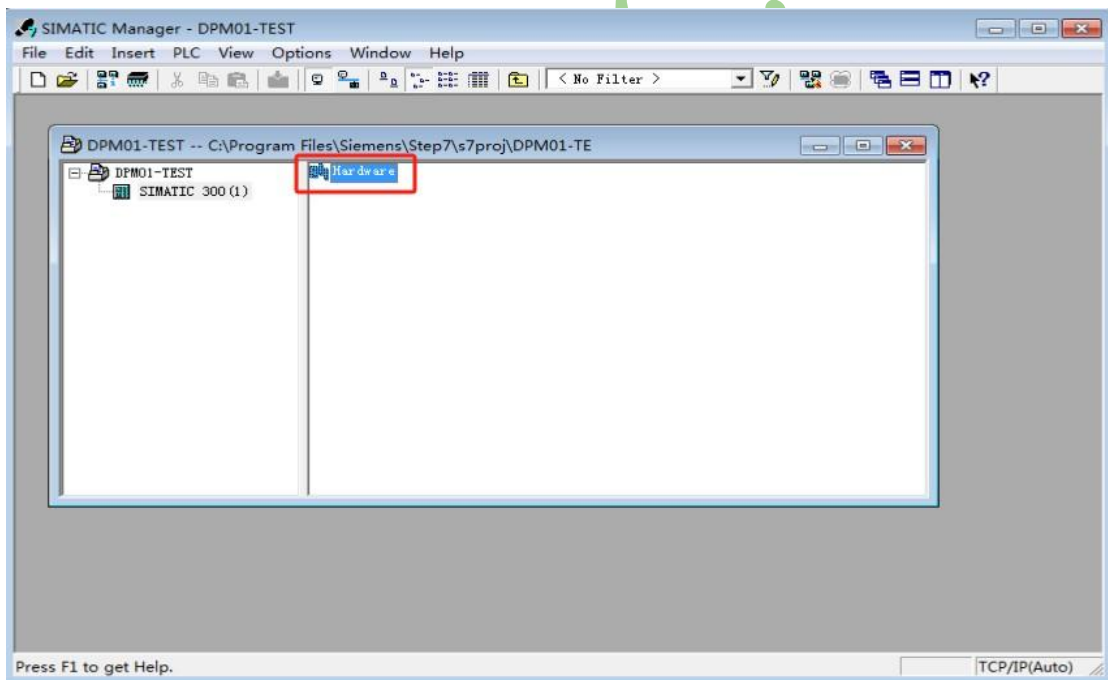
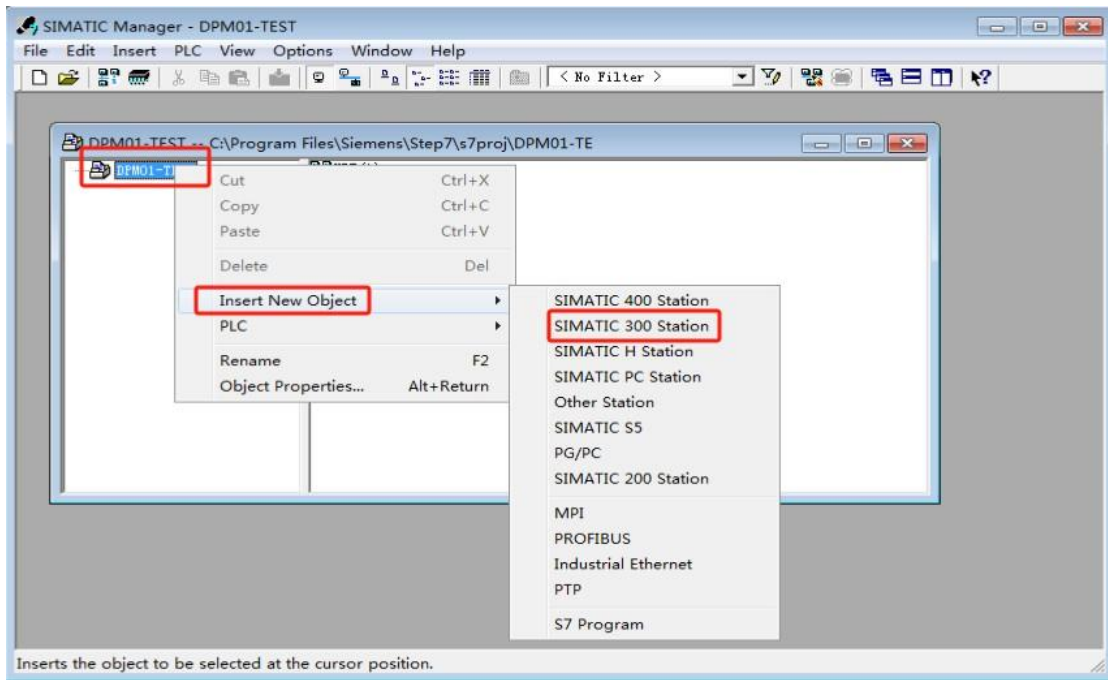

4 Before configuring the hardware, click on "Options" in the menu bar, click "Install GSD File", click "Browse" in the pop-up box, and navigate to the directory where DPM01_V2.GSD is located. In this case, it is C:\Users\Administrator\Desktop\DPM01 GSD. In the "Install GSD File" interface, click "Install", and then click "Yes".

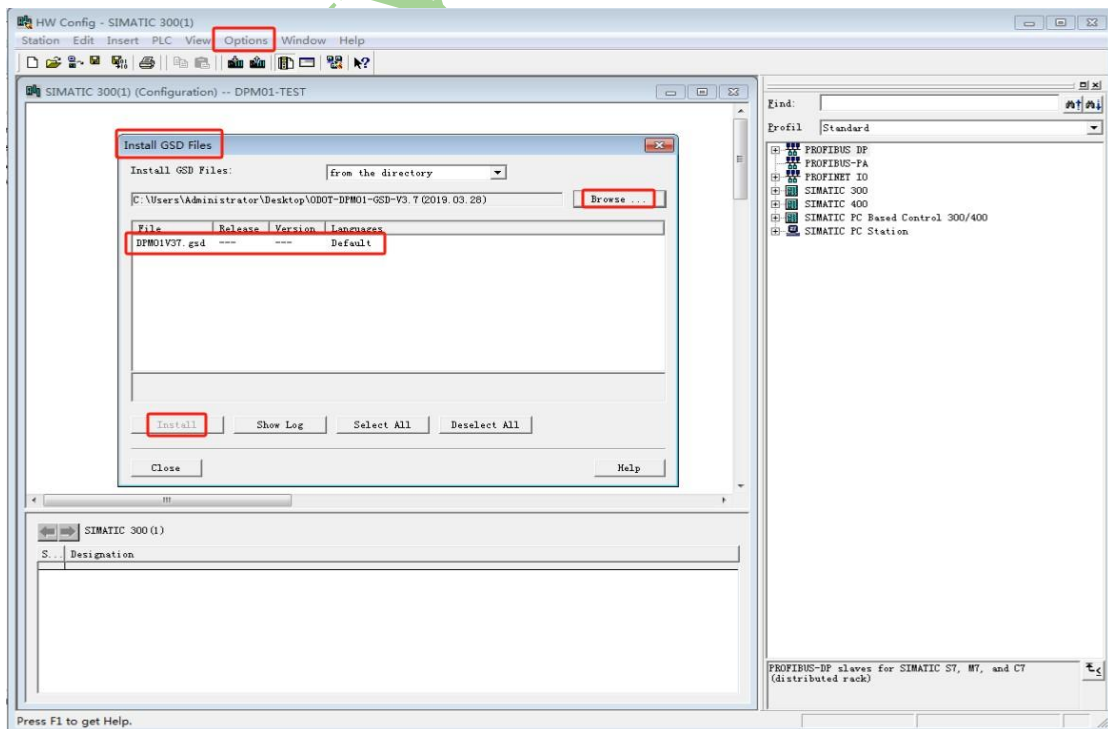
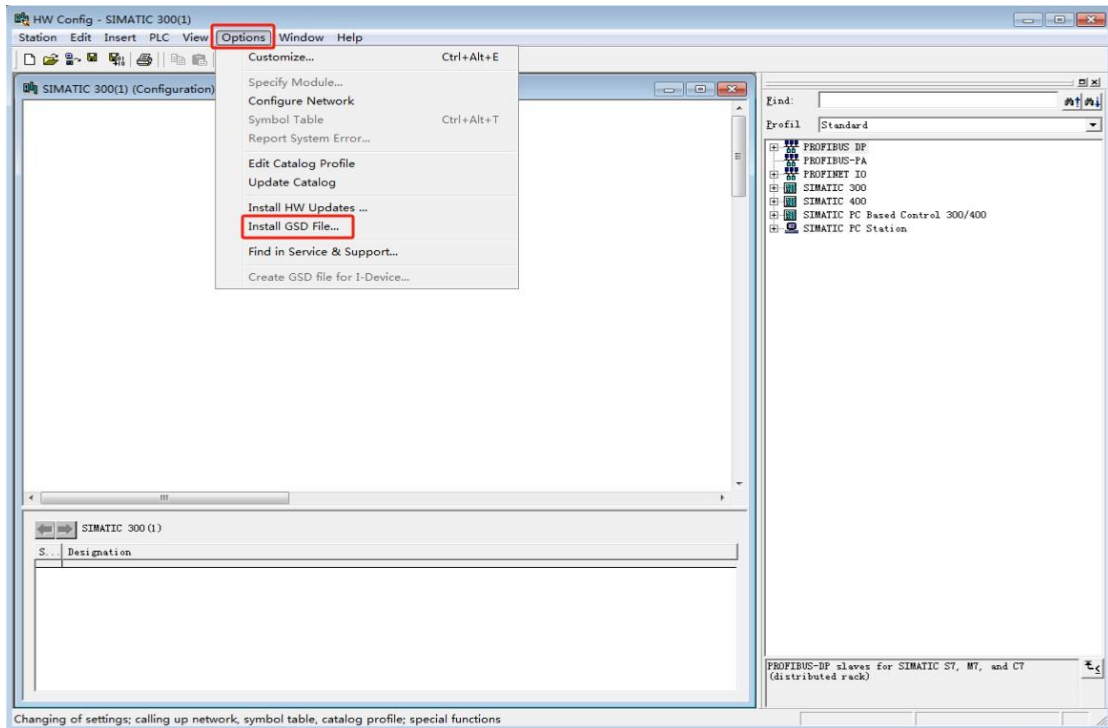

5 Click on "Options" in the toolbar and then click on "Update Catalog" in the drop-down menu.

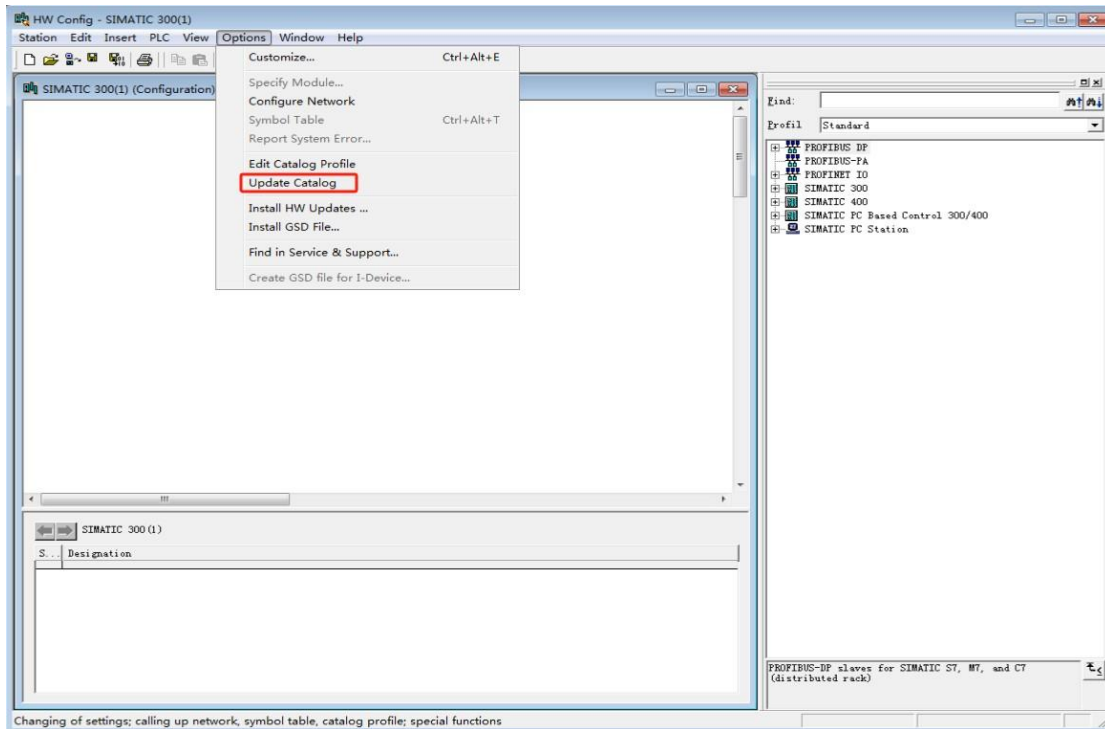

6. Gateway device “DPM01 V2.0” can be found in “PROFIBUS-DP”-“Additional Field Devices”-“Gateway”.

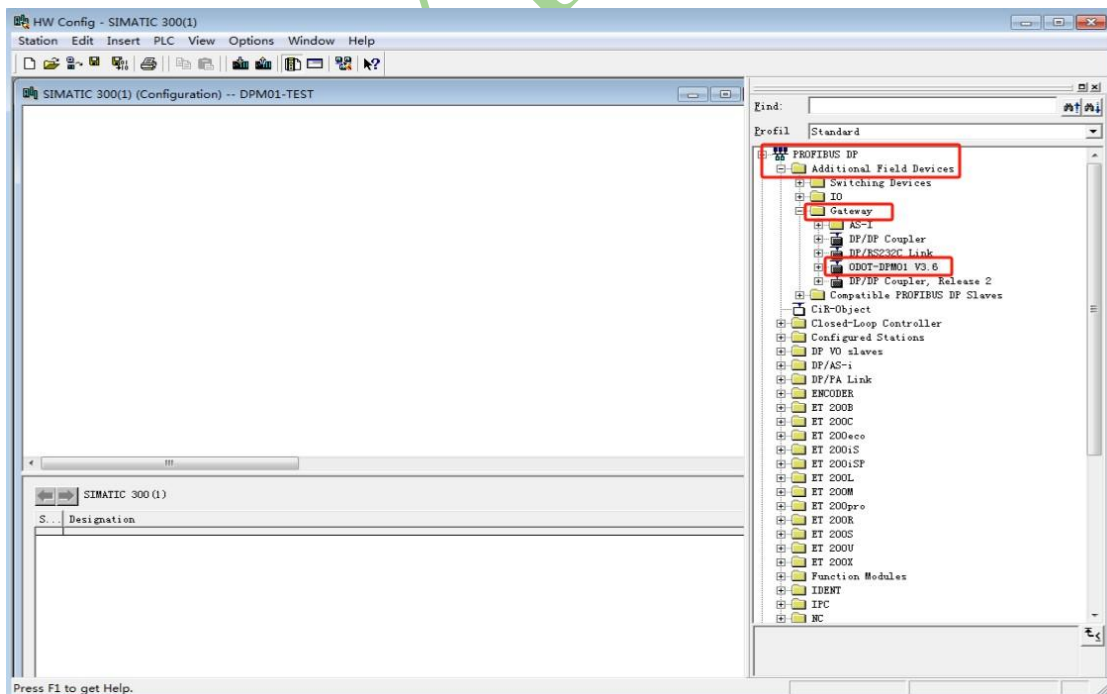

7 Start configuring the hardware, first place the Rail, and then place the power module and CPU module in slots 1 and 2 respectively. When adding a CPU, a PLC Ethernet interface parameter window will pop up, fill in the IP address of the PLC, and create a new subnet.

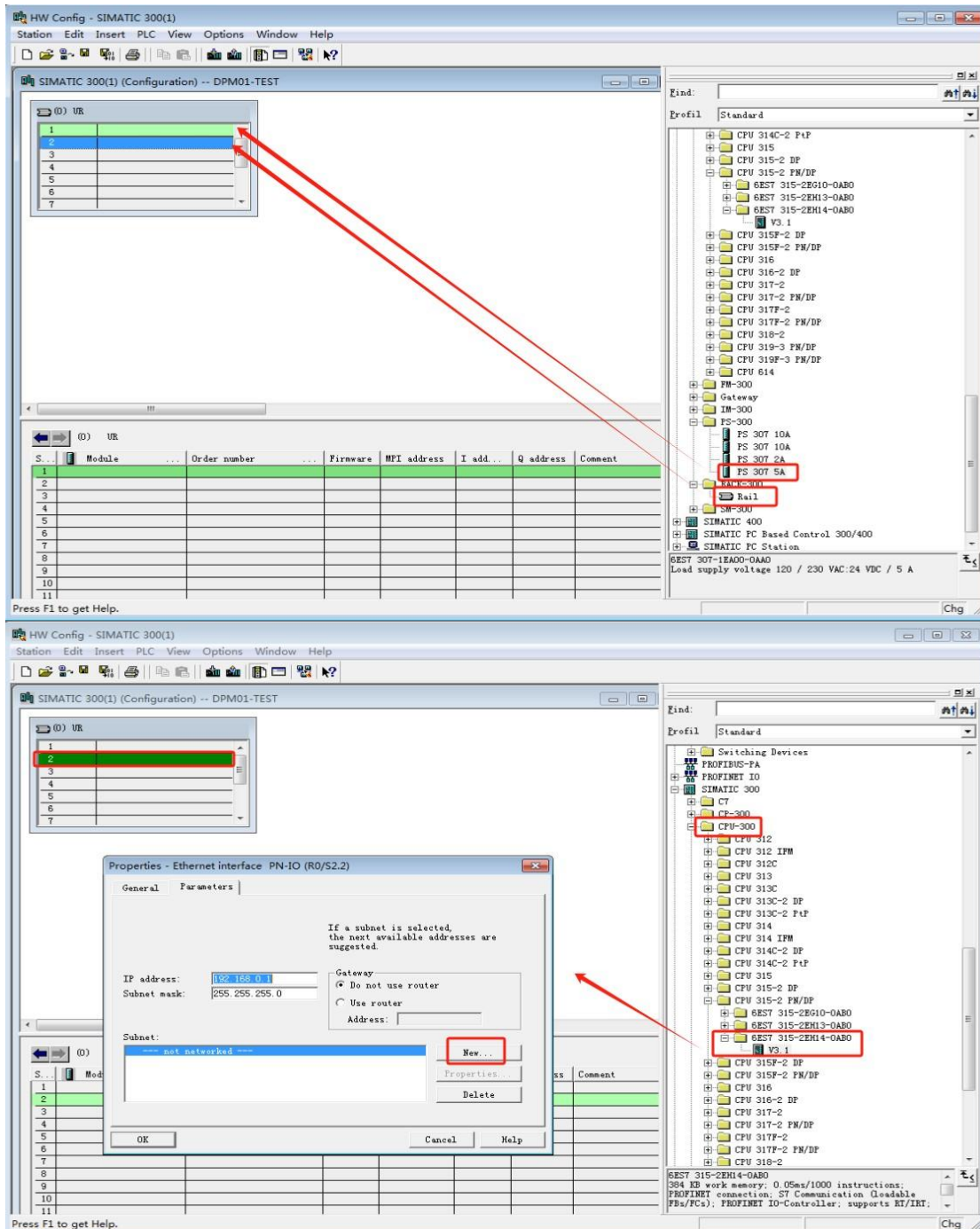

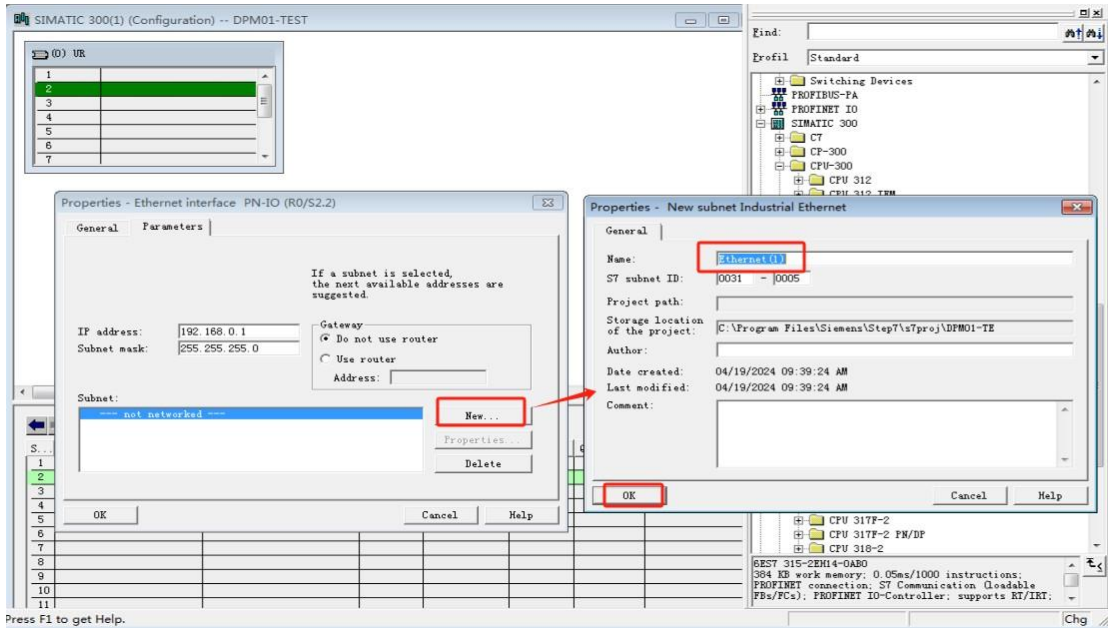

After adding the CPU, double-click on CPU 315-2 PN/DP, click on Cycle/Clock Memory in the pop-up interface, and modify the process image input/output area size. Default 128, increase to 2000.

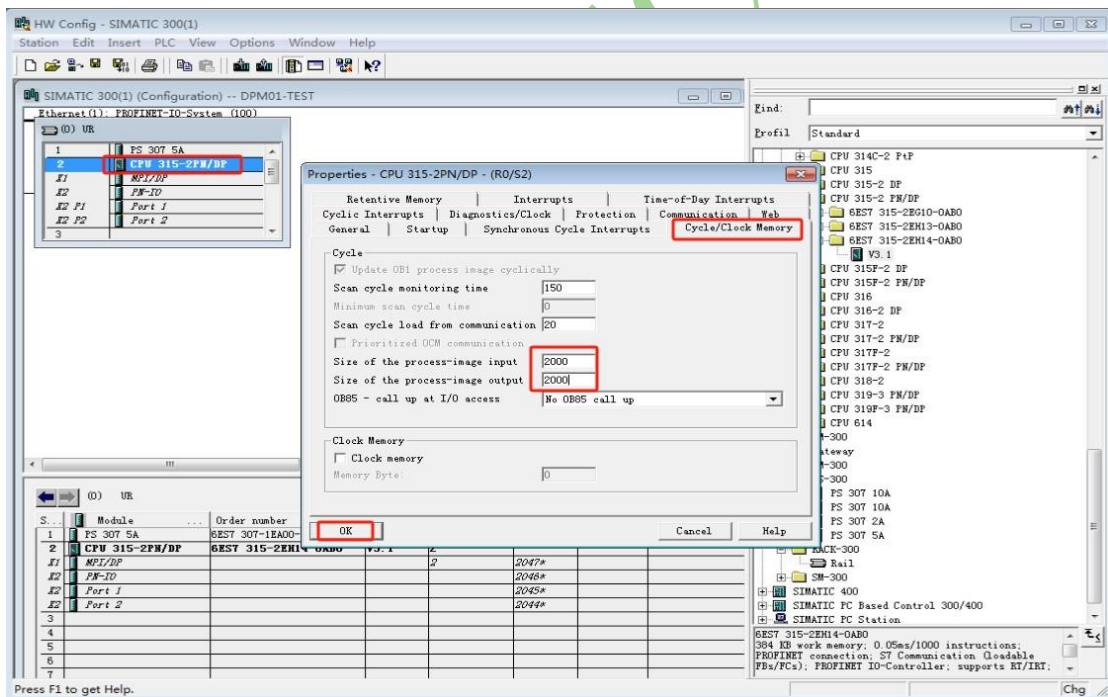

8. Double click on "X1 MPI/DP", select the interface type: PROFIBUS, and a PROFIBUS interface parameter box will pop up. Click on "New Subnet" and "OK" to complete the establishment of the DP master station system.

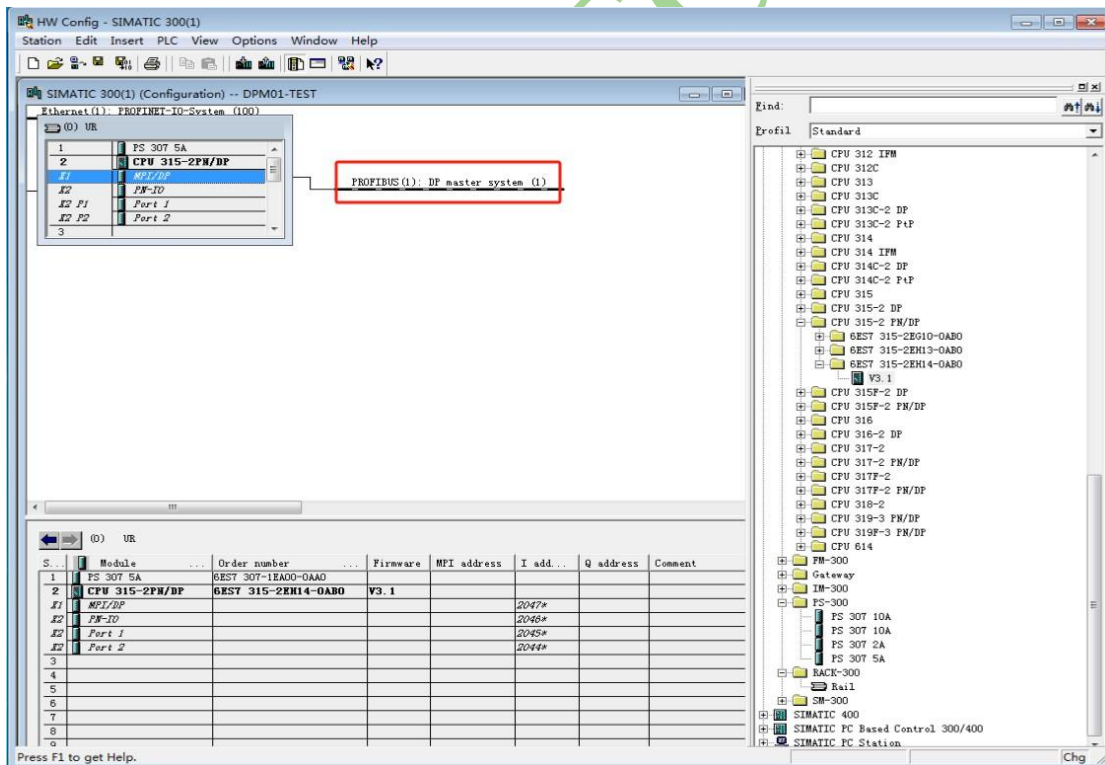
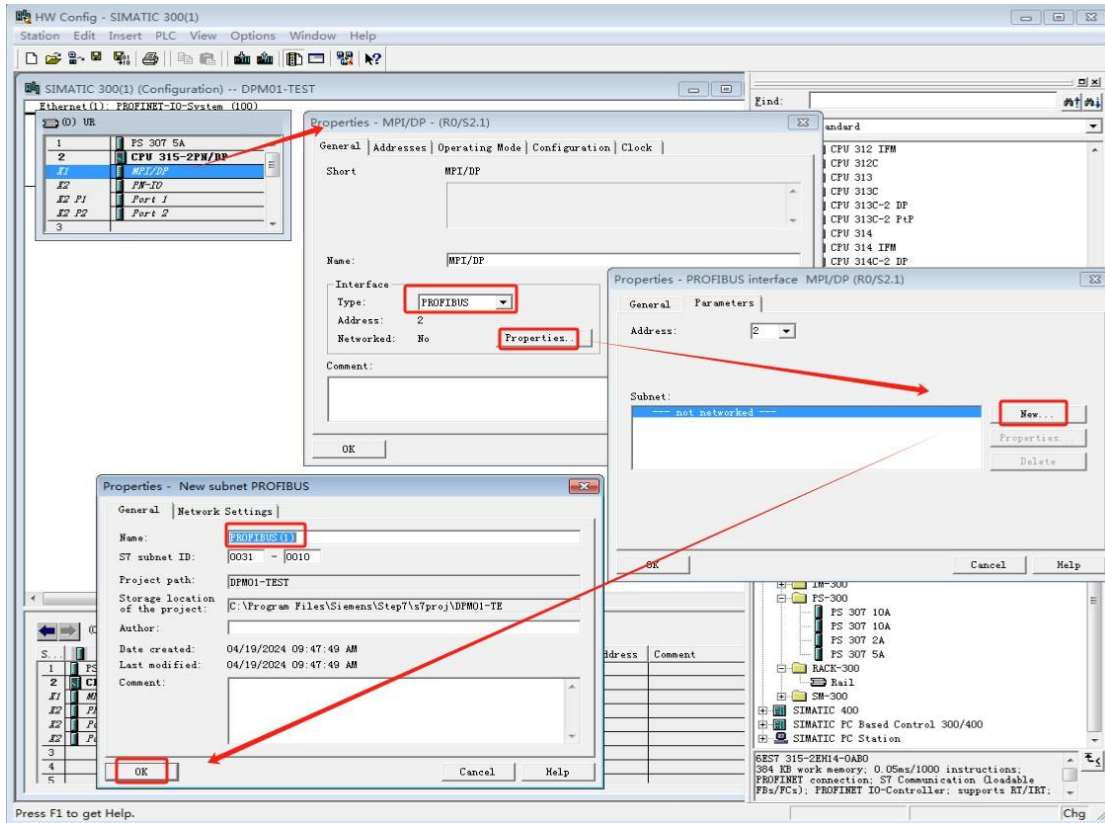

9. Drag and drop the gateway device DPM01 directly onto the DP bus, and a PROFIBUS interface parameter window will pop up. Fill in the DPM01 address, which should be consistent with the address set on the DPM01 gateway hardware dial switch. Click OK. Complete the addition of the gateway.

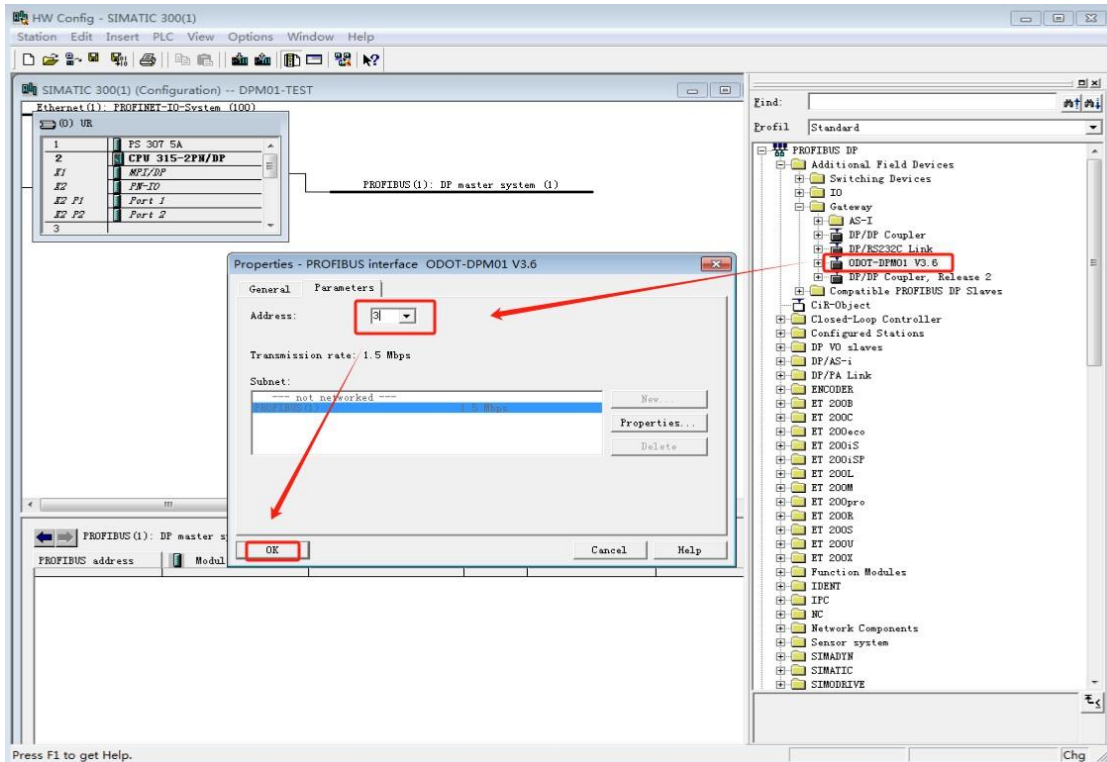

10. Double click on the gateway icon and the following configuration will appear:

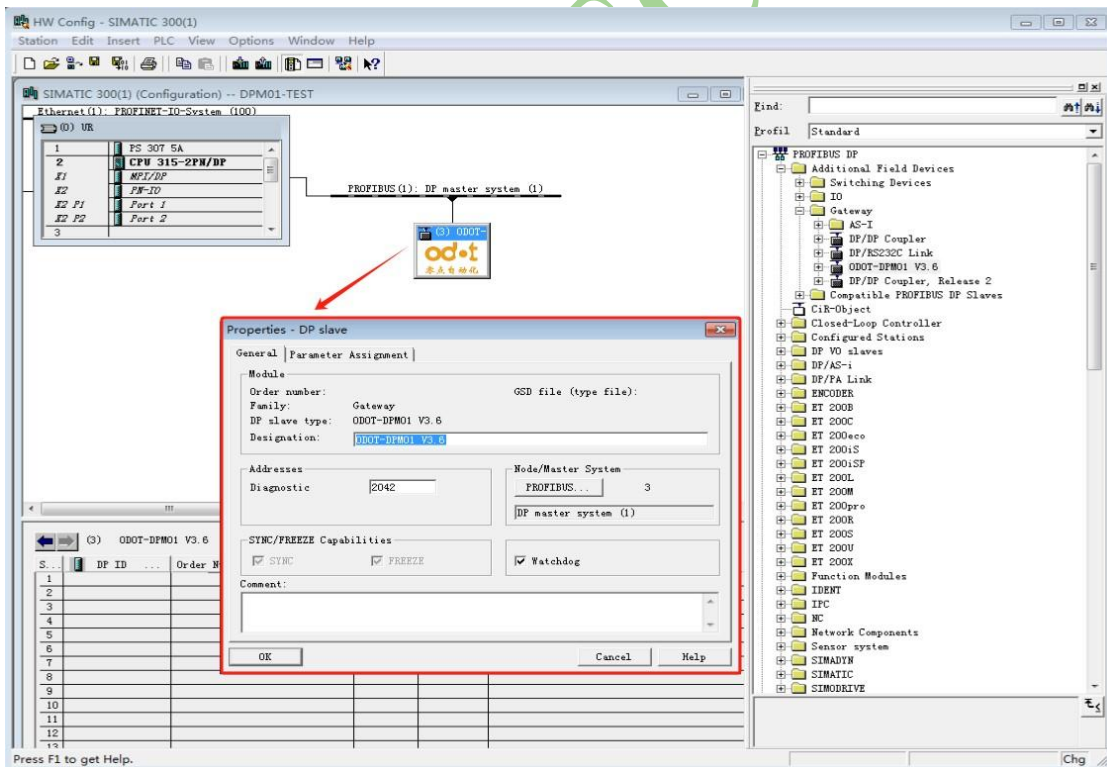

Click "Assign Parameters" again to set the Modbus parameters for the gateway (which must match the RS485 device connected to the user). After setting, click the "OK" button, as shown in the following figure:

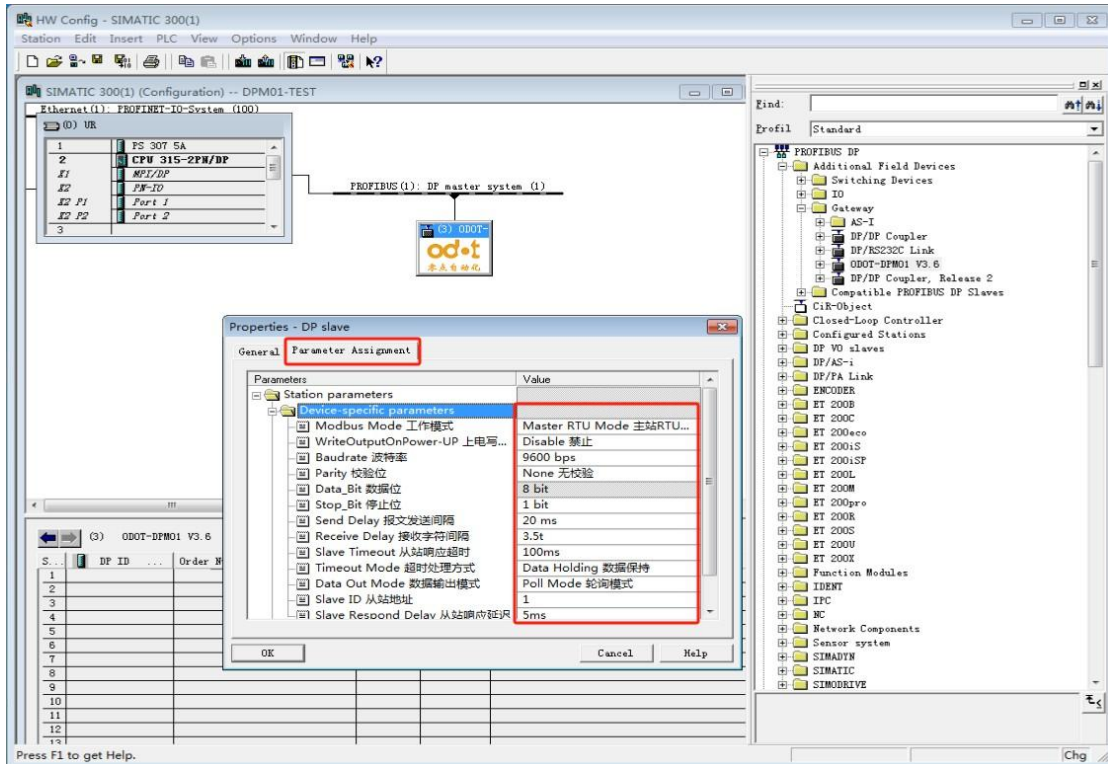

11. Device specific parameter settings:

Modbus Mode 工作模式 :

Master Mode 主站模式。

Baudrate 波特率 :

Serial baud rate, optional range 1200~115200bps, default 9600bps.

Parity 校验位 :

You can choose no parity, odd parity, or even parity, with no parity by default.

Data_Bit 数据位 :

Fixed to 8-bit data.

Stop_Bit 停止位 :

1 or 2 stop bits are optional, default to 1 stop bit.

Send Delay 报文发送间隔 :

The interval time for sending Modbus commands (the delay from receiving the response message from the slave station to sending the next command) is optional from 0ms to 5000ms, with a default of 20ms.

Receive Delay 接收字符间隔 :

The frame interval detection time when receiving a message is optional from 1.5t to

200t, with a default of 3.5t (t is the time for transmitting a single character, which is related to the baud rate).

Slave Timeout 从站响应超时 :

The time it takes for the slave station to respond after the master station sends a command. 10ms~5000ms optional, default to 100ms.

Timeout Mode 超时处理方式 :

After reading data from the station timeout, the data processing method can be selected as "data reset" or "data hold". The default "data hold" mode is only valid for Modbus read commands.

Data Out Mode 数据输出模式 :

You can choose between "Polling Mode" or "Event Triggering" mode, in which Modbus periodically sends write messages. In the "event triggered" mode, write commands are only sent when the Modbus output data changes. The default is "polling mode", which is only valid for Modbus write commands.

Slave ID :

This parameter is invalid for the Master mode.

Slave Respond Delay 从站响应延迟 :-

This parameter is invalid for the Master mode.

12. Modbus Master Station Mode Data Command Configuration:

The Master station module starts with M: and can only be used in Modbus Master mode.

Note: When the MODBUS side slave equipment needs to use function code 05 (to write a single coil), please use M: Write single bit (0xxxx). When the MODBUS side slave equipment needs to use function code 06 (to write a single register), please use M: Write single word (4xxxx).

Click on the gateway icon and insert the desired read and write command into the slot. Insert two diagnostic commands into the first two slots. Insert the third slot into "M: Read 8 Word (3xxxx)". Note: The RS485 device is simulated using the testing software Modbus Slave.

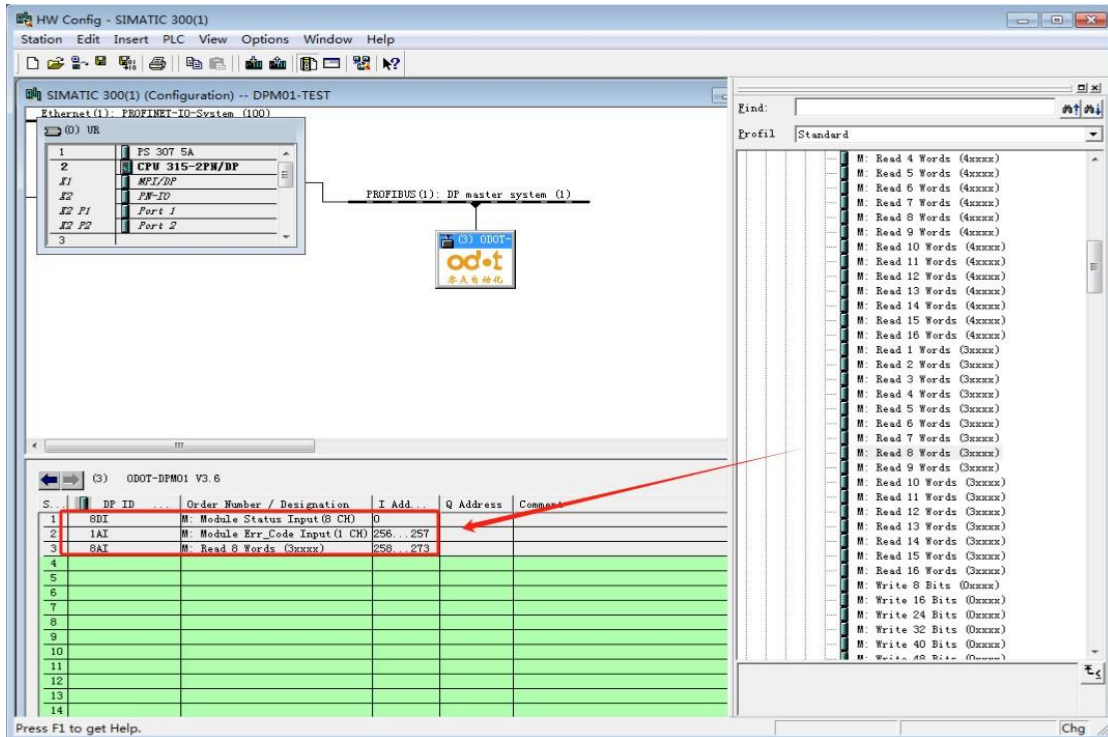

Double click on the added function block "Read 8 Words (3xxxx)" to configure its parameters. The Slave ID slave number must be consistent with the corresponding Modbus address set by the slave, and the "start address" refers to the starting address of the Modbus cache area that needs to be read. For example, in this example, the Modbus slave used is 1, and the Modbus address table is 0.

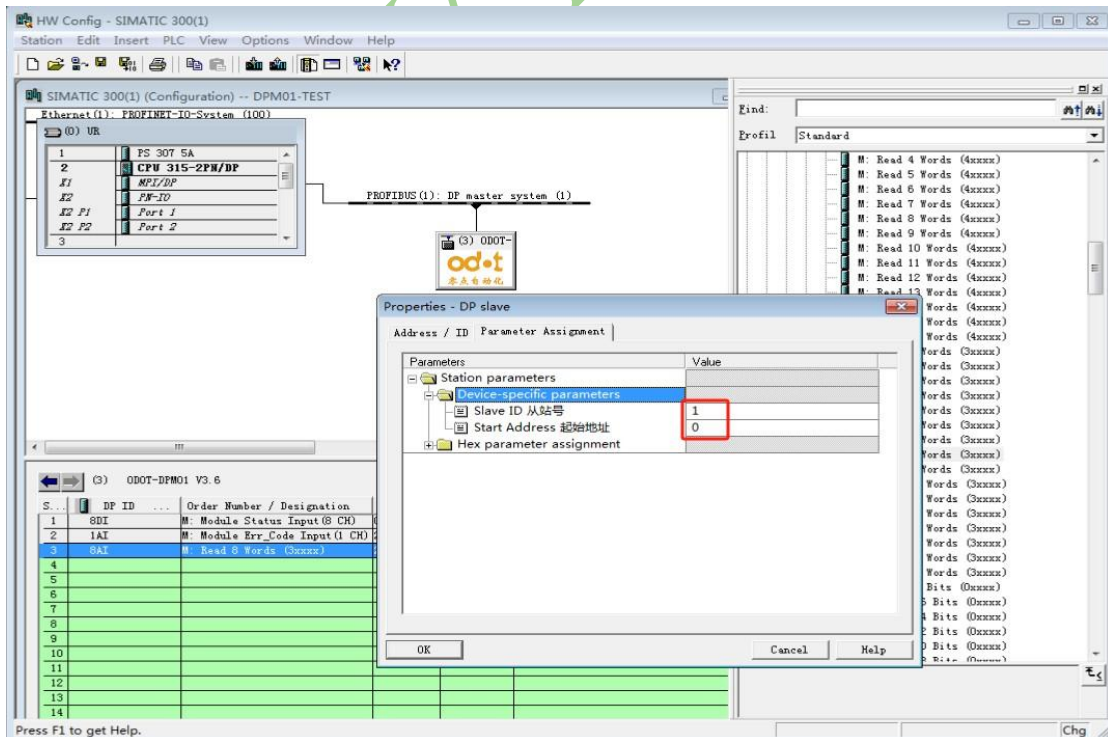

Note: When the slave address code starts from 1, it indicates that its address code is a PLC address. At this time, "start address" is the actual PLC address in the address

table minus 1. When the slave address code starts from 0, "start address" is the actual encoded address in the address table.

According to the actual situation, other data modules can be inserted into the later slots.

- Click "Save and Compile", and if there are no errors, click "Download". Click "OK" - "Yes" in the pop-up interface.

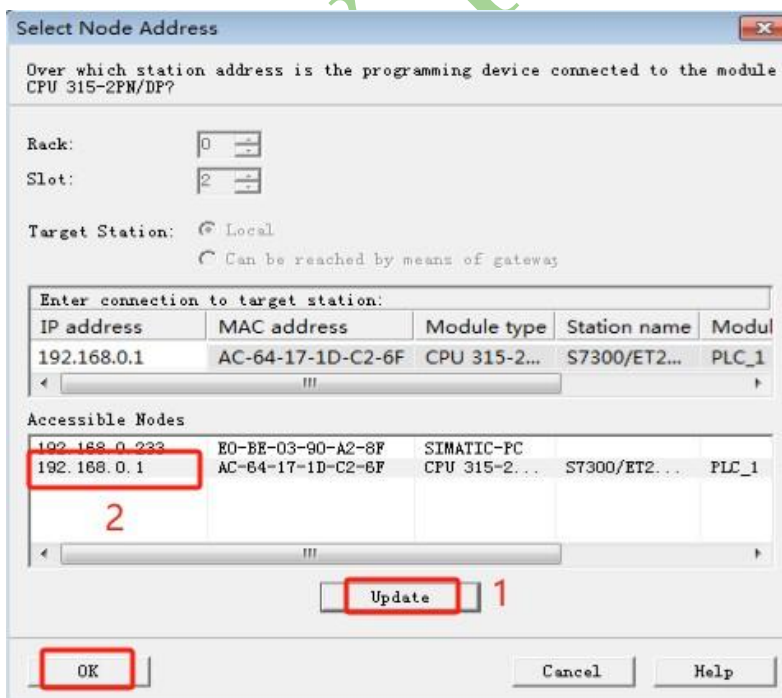
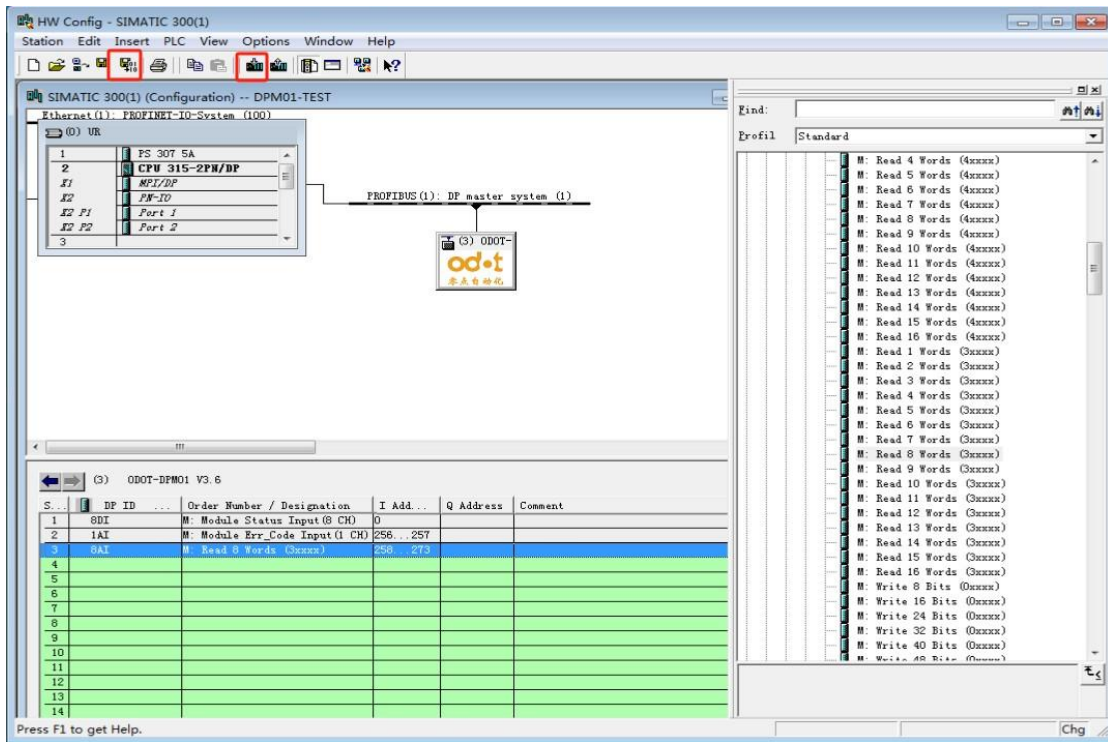

14. Right click on the "8AI" module in slot 3, then click "Monitor/Modify", and select "Monitor" in the pop-up board to read the values of each channel. The red box in the figure below is the value read in this example.

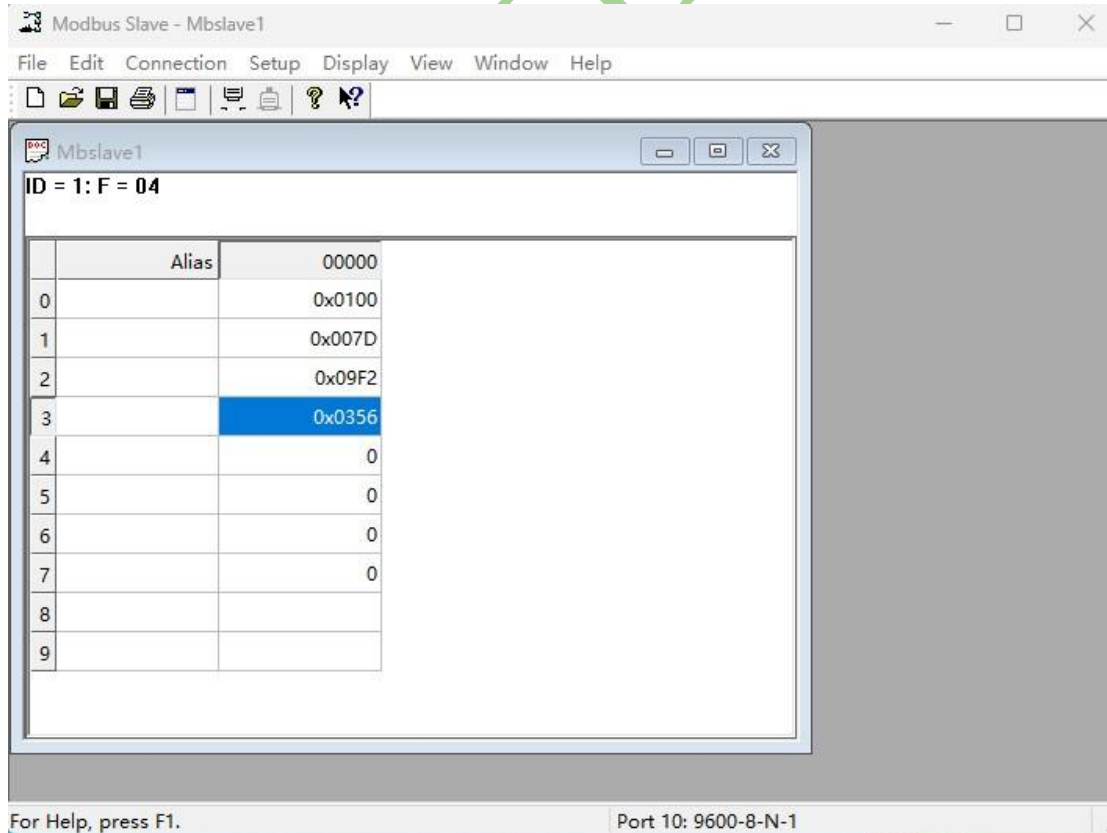
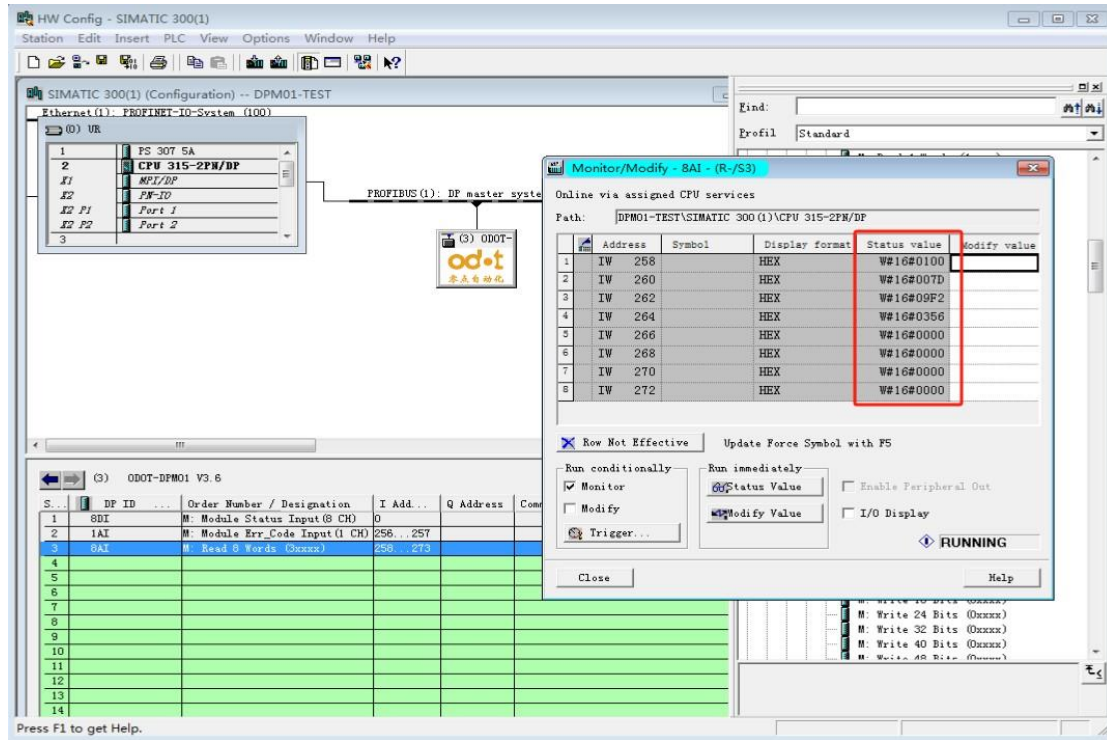

The above figure shows the use of AI modules, which are similar to DI, DO, AO modules, and other standard Modbus devices. (Note: I and Q addresses can be changed by oneself) 15. Mater diagnostic module

The Master diagnostic module is a selectable module and can only be used in Modbus Master mode. The Master diagnostic module is divided into two types: "Slot Status Input" and "Slot Error Code Input Module ErrCode Input". At most one module can be inserted into each of the two types. The status module can only be inserted into slot 0, while the error code module can be inserted into slots 0 and 1. When the error code module is inserted into slot 1, slot 0 can only be inserted into the status module.

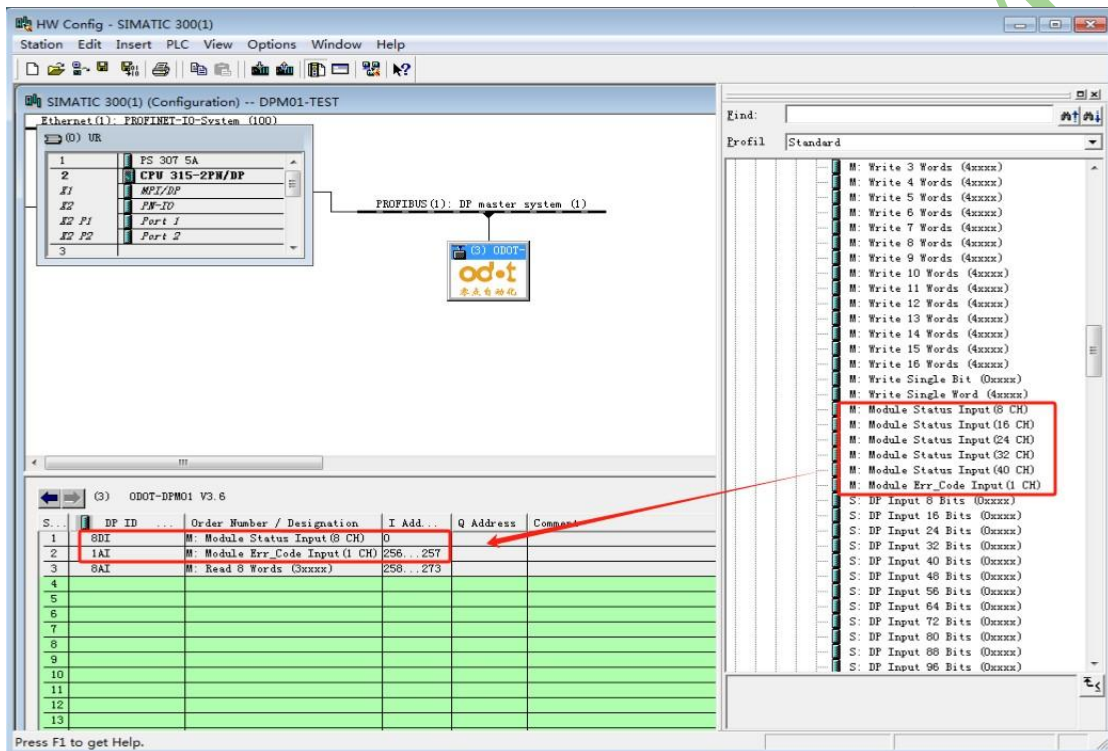

The status module can monitor the working status of each data slot. When a data slot fails, the corresponding status bit is set to 1, and it automatically resets to zero after the fault is restored.

When a data slot malfunctions, the error code module can display the serial number and specific error code of the erroneous data slot. Users can determine the cause of the malfunction based on the error code and take corresponding adjustment methods.

Please refer to the "Error Code Table" for a detailed description.

The error code module can only display the fault status of one slot. When multiple slots fail simultaneously, the error code module will display the fault status of the slot with the lowest serial number in the error slot.

Right click on slots 0 and 1, select "Monitor/Modify", and check "Monitor" in the pop-up panel to display module status and error codes.

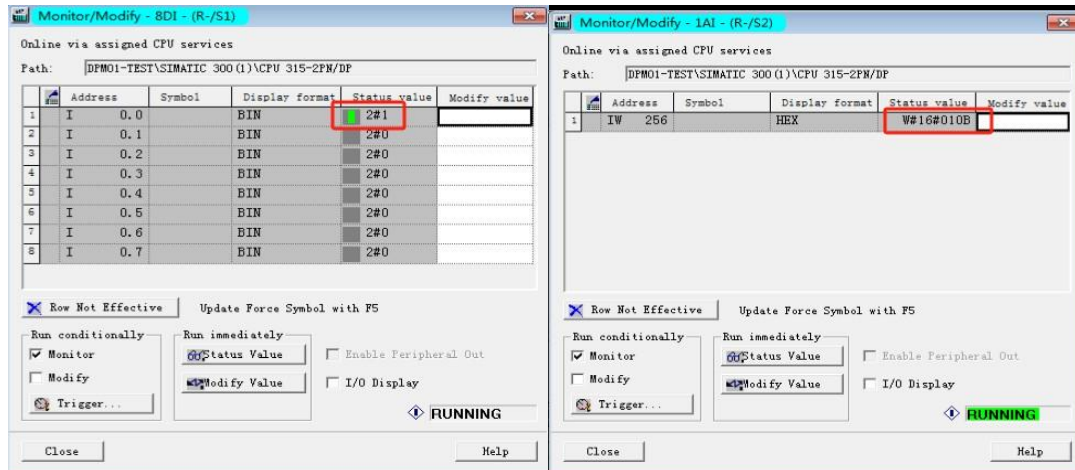

As shown in the above figure, when the corresponding slot module fails, the module status corresponding bit is set to 1. The error code is 0x010B, where 0x01 indicates a fault in the first data slot and 0x0B indicates a "slave response timeout". Other error codes are shown in the table below.

Modbus Master Error Code Table

Error Code	Fault description	Troubleshooting method
0x00	Working properly	N/A
0x01	Illegal function code	The device does not support the current function code, please refer to the slave manual to select the corresponding function code module
0x02	Illegal data address	If the device data exceeds its address range, refer to the slave manual to modify the data starting address or data length
0x03	Illegal data value	Data length error, data length beyond the Max. allowed value 125(Word) or 2000(Bit), modify the length

0x04	Slave device error	Check the status of the slave device
0x06	Slave device busy	Check the status of the slave device
0x07	parity error	Check parity, baud rate, stop bit, and hardware connection status
0x09	CRC verification error	Slave response message CRC calculation error, check the working status of the slave
0x0B	Slave device response timeout	Increase the timeout time, check the hardware connection status, and view communication parameter settings such as baud rate
0x0E	Response message length error	Increase the receive character spacing
0x0F	Write slave device response error	Check the hardware connection state

Note: The testing method for setting the Modbus ASCII master mode of the RS485 interface is the same as the testing method for setting the master mode of the Modbus RTU protocol. Only the working mode of the gateway needs to be changed to the corresponding Modbus ASCII master mode.

4.2 Modbus RTU Slave Mode

1.Modbus Slave Mode Data Address Table

Data area	Effective address range
Zone 0 (0XXXX)	0~1951
Zone 1 (1XXXX)	0~1951
Zone 3 (3XXXX)	0~121
Zone 4 (4XXXX)	0~121

2→10 Refer to 4.1 (Master Station Mode)的 1→9。

11. Double click on the gateway icon and the following configuration will appear.

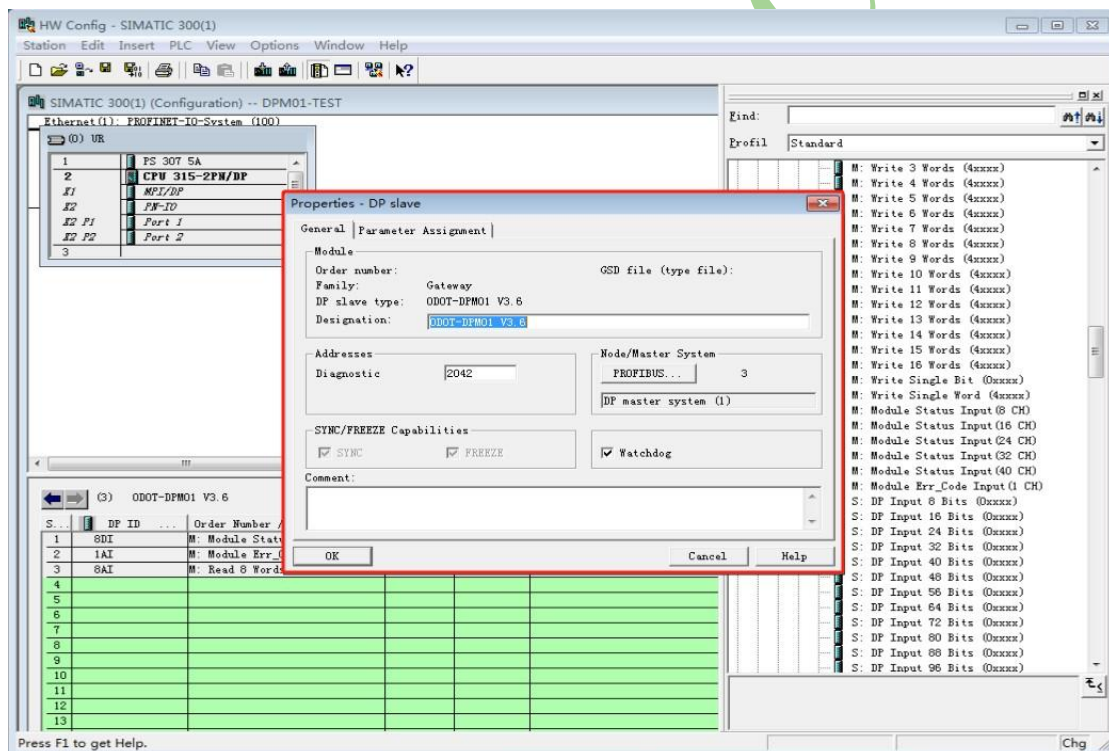

Click "Assign Parameters" again to set the Modbus parameters for the gateway (which must match the RS485 device connected to the user). After setting, click the "OK" button, as shown in the following figure:

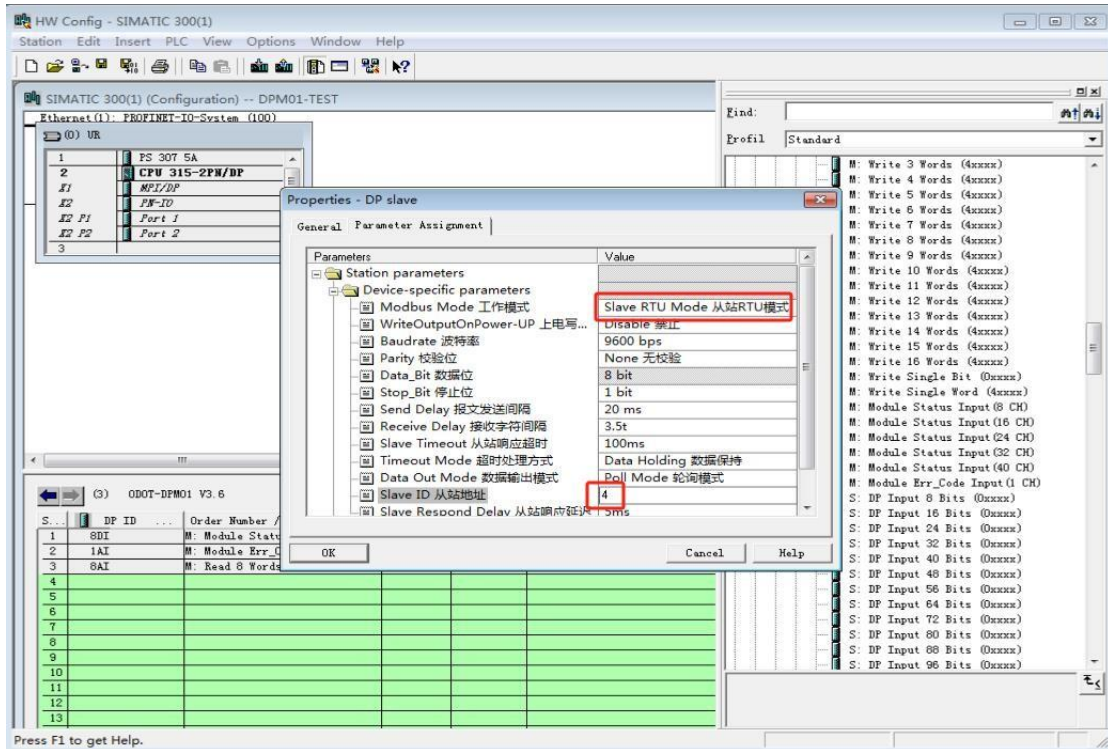

Modbus Mode 工作模式:

Slave Mode 从站模式。

Baudrate 波特率 :

Serial baud rate, optional range 1200~115200bps, default 9600bps.

Parity 校验位 :

You can choose no parity, odd parity, or even parity, with no parity by default.

Data_Bit 数据位 :

Fixed to 8-bit data.

Stop_Bit 停止位 :

1 or 2 stop bits are optional, default to 1 stop bit.

Send Delay 报文发送间隔 :

This parameter is invalid for the slave mode.

Receive Delay 接收字符间隔 :

The frame interval detection time when receiving a message is optional from 1.5t to 200t, with a default of 3.5t (t is the time for transmitting a single character, which is related to the baud rate).

Slave Timeout 从站响应超时 :-

This parameter is invalid for the slave mode.

Timeout Mode 超时处理方式：

This parameter is invalid for the slave mode.

Data Out Mode 数据输出模式：

This parameter is invalid for the slave mode.

Slave ID：

Slave ID number, valid range is 1-247, default value is 1.

Slave Respond Delay 从站响应延迟：

The response delay time of the slave station is when the slave station receives a request message from the master station, processes the data, delays for a certain length of time, and then replies to the data message. 0ms~2000ms optional, default 5ms.

12. Modbus slave mode data command configuration

The module starting with S: is a slave module and can only be used in Modbus slave mode.

13. Insert the Modbus slave status module in slot 0, and an input module "DP Input 8 Words (4xxxx)" in slot 1, filling in the starting word address of the Modbus 4xxxx area.

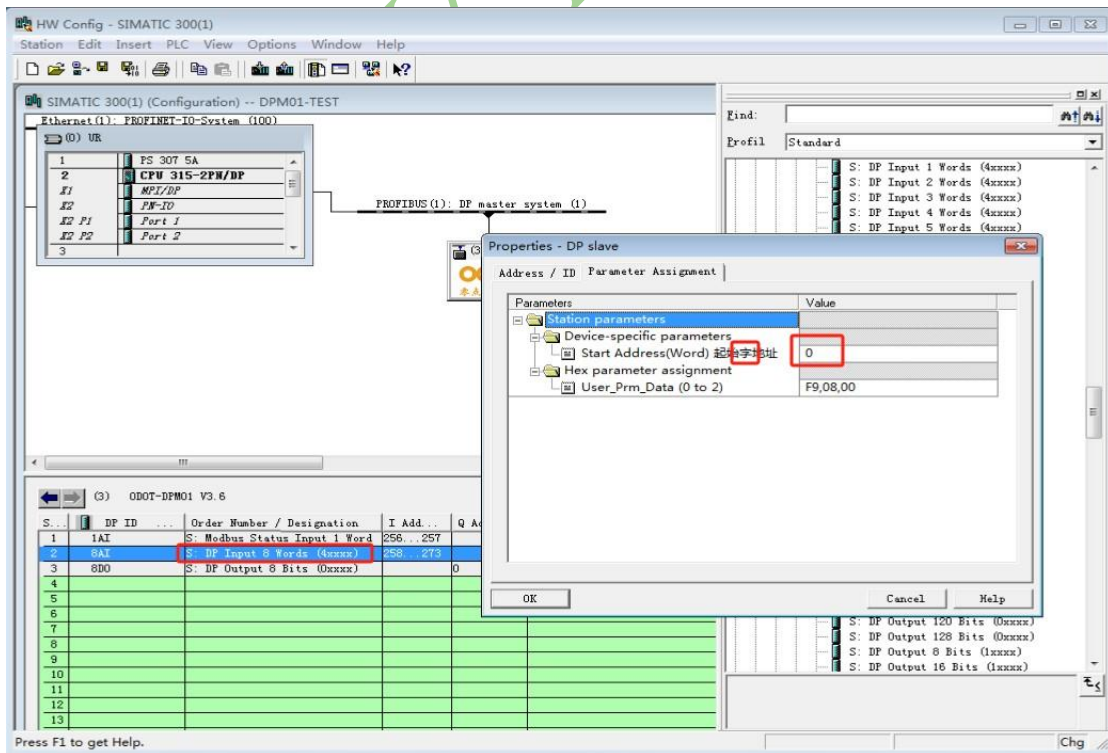

14. Insert an output module "DP Output 8 bits (0xxxx)" into slot 2 and fill in the starting byte address of the Modbus 0xxxx area.

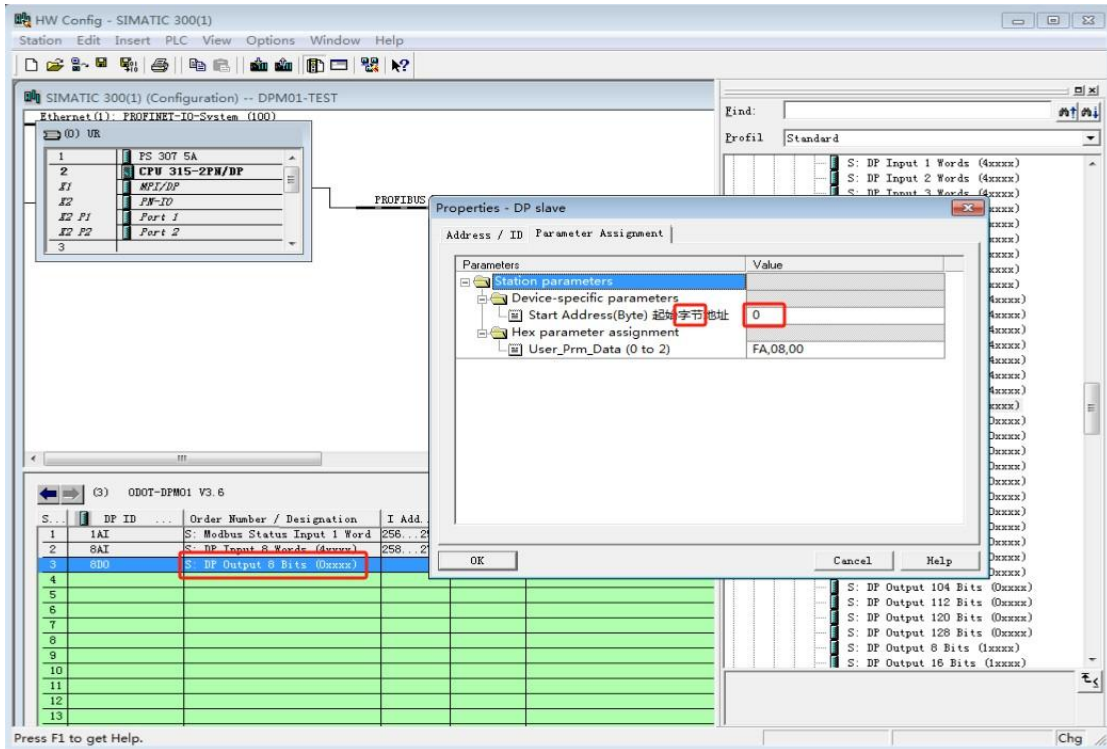

15. Download the configuration program to the PLC after saving and compiling.

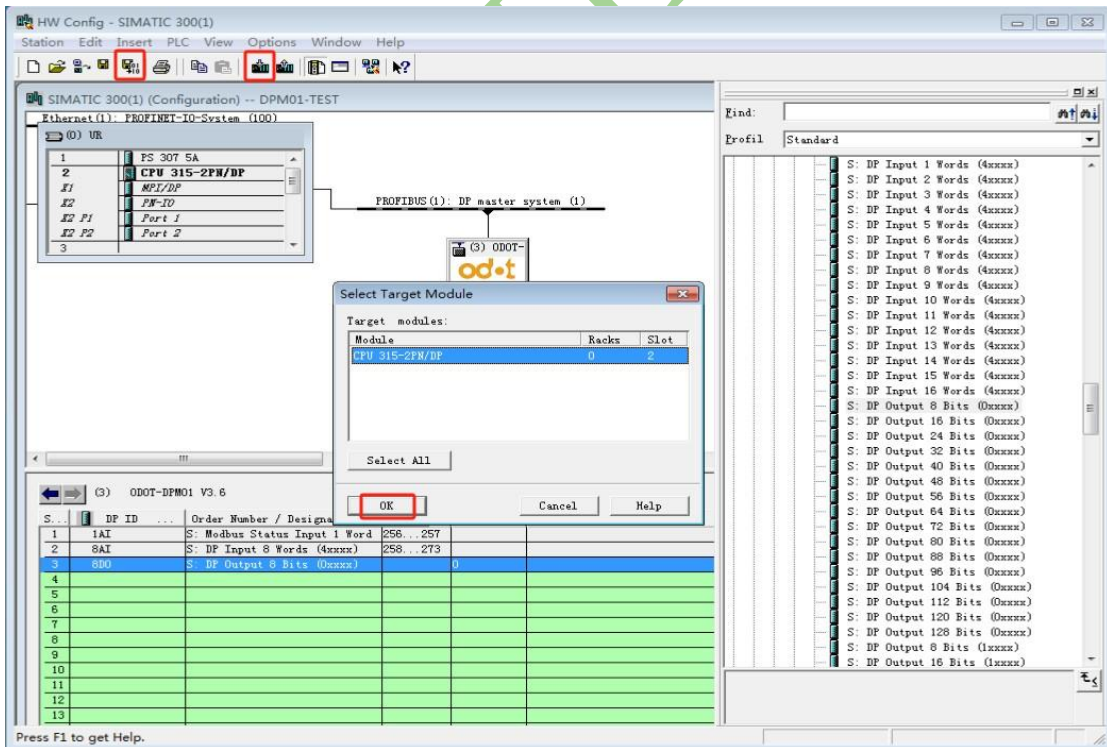

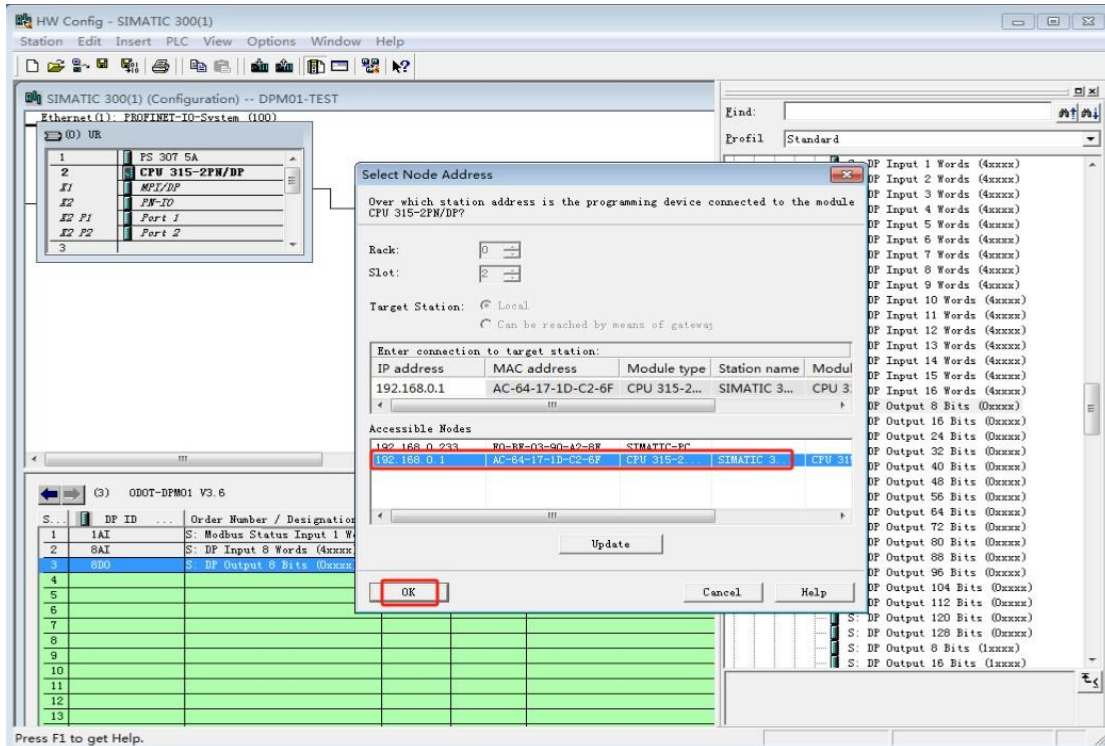

16. Right click on slots 2 and 3, click "Monitor/Modify", and then select "Monitor" to see the DP input data. The monitoring data value is consistent with the data written by the Modbus Poll (used to simulate the RS485 device master station) master station, as shown in the following figure.

Modbus Poll Master Station Write Data:

DP Input Data:

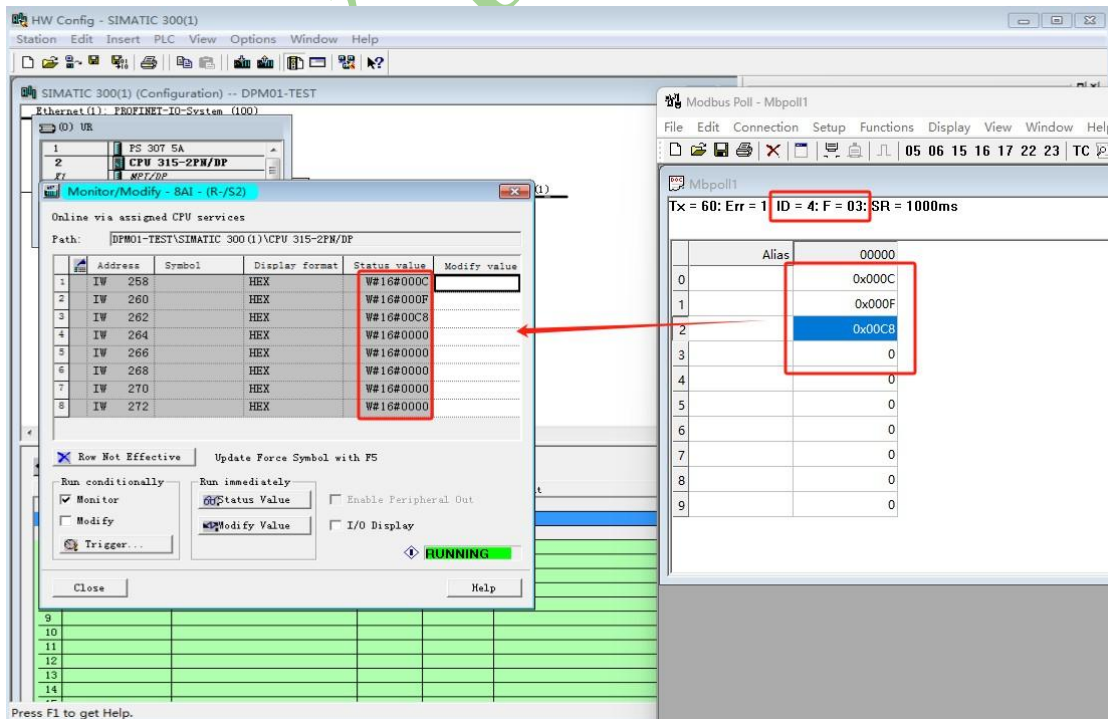

17. Modify the output value in DP output data, and then click the modify button, as shown in the following figure.

Modbus Poll reads data from Modbus slave station:

DP output data:

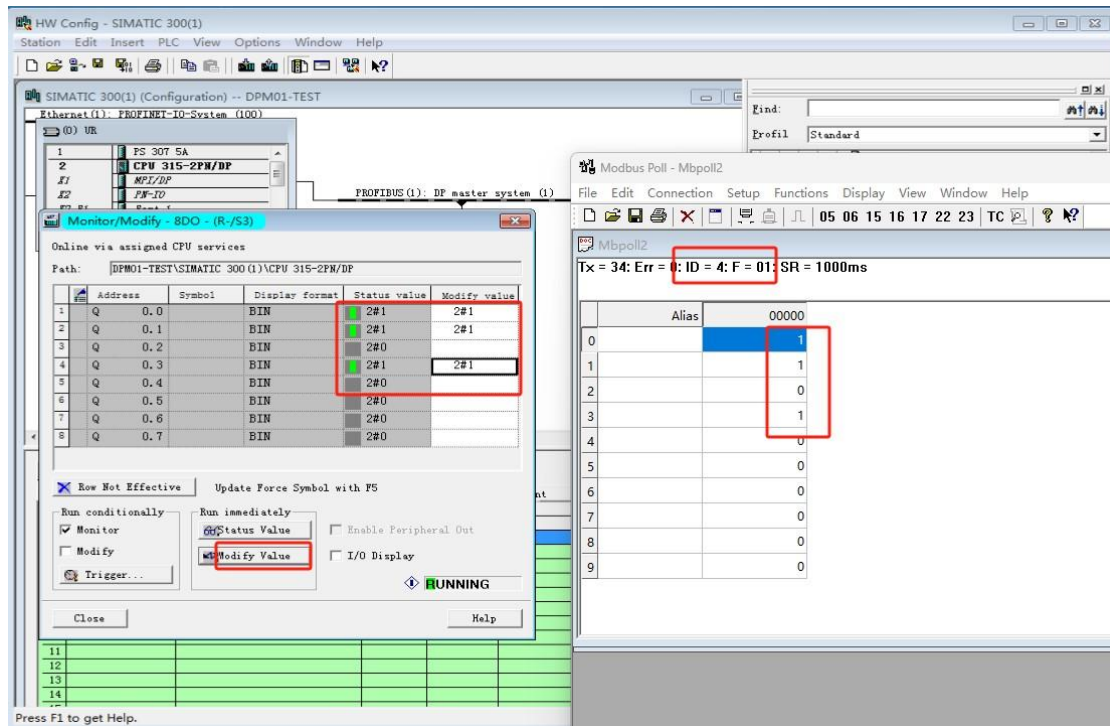

18. Modbus slave status module

The Modbus slave status module can only be used in slave mode, and the DP side can read the slave status to determine the working status of the Modbus slave. When the slave station is working normally, the error code is 0. When an error occurs at the slave station, the error code will indicate the cause of the error. Error codes are shown in the table below:

Modbus Slave Error Code Table

Error Code	Fault description	Troubleshooting method
0x00	Working properly	N/A
0x01	Illegal function code	The device does not support the current function code, please refer to the slave manual to select the corresponding function code module
0x02	Illegal data address	If the device data exceeds its address range, refer to the slave manual to modify the data starting address or data length

0x03	Illegal data value	Data length error, data length beyond the Max. allowed value 125(Word) or 2000(Bit), modify the length
0x07	parity error	Check parity, baud rate, stop bit, and hardware connection status
0x09	CRC verification error	Slave response message CRC calculation error, check the working status of the slave
0x0E	Response message length error	Increase the receive character spacing

Note: The testing method for setting the Modbus ASCII slave mode of the RS485 interface is the same as the testing method for setting the slave mode of the Modbus RTU protocol. Only the working mode of the gateway needs to be changed to the corresponding Modbus ASCII slave mode.

5 Testing application in Siemens TIA V16

This chapter will use SIEMENS CPU 315-2 PN/DP as the PROFIBUS Controller and TIA as the configuration software to illustrate the configuration method of DPM01.

5.1 Modbus RTU Master Mode

1. Download the GSD folder of DPM01 from the official website and confirm that there are the following files in the folder. If not, please contact the supplier to request them.



2. Open TIA V16 software, create a new project named DPM01-TEST, with no Chinese characters in the storage path. Click Create and then click on the project view in the bottom left corner.

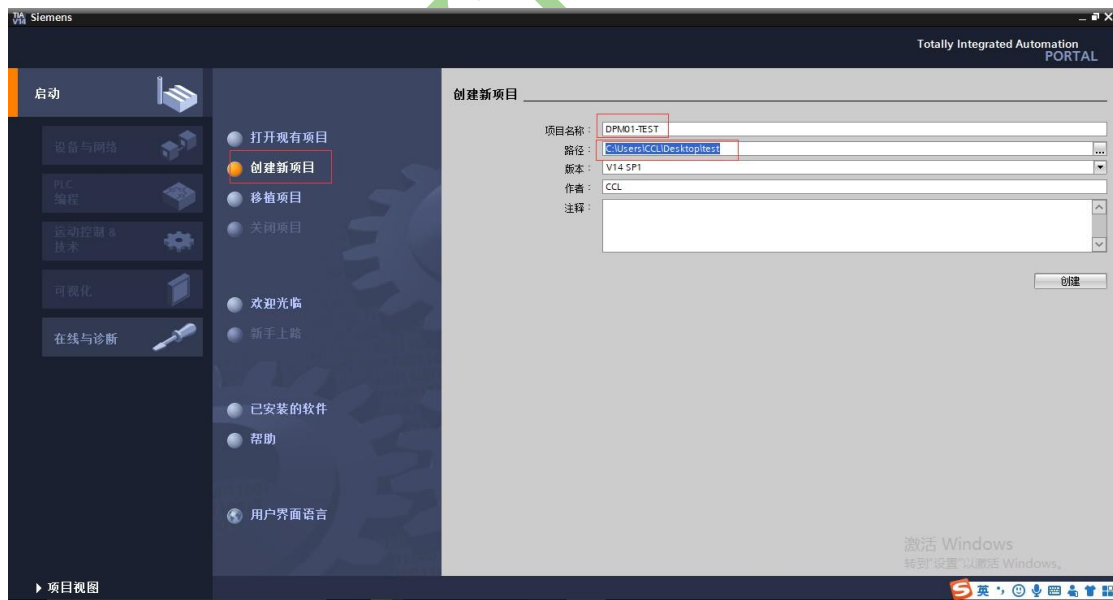

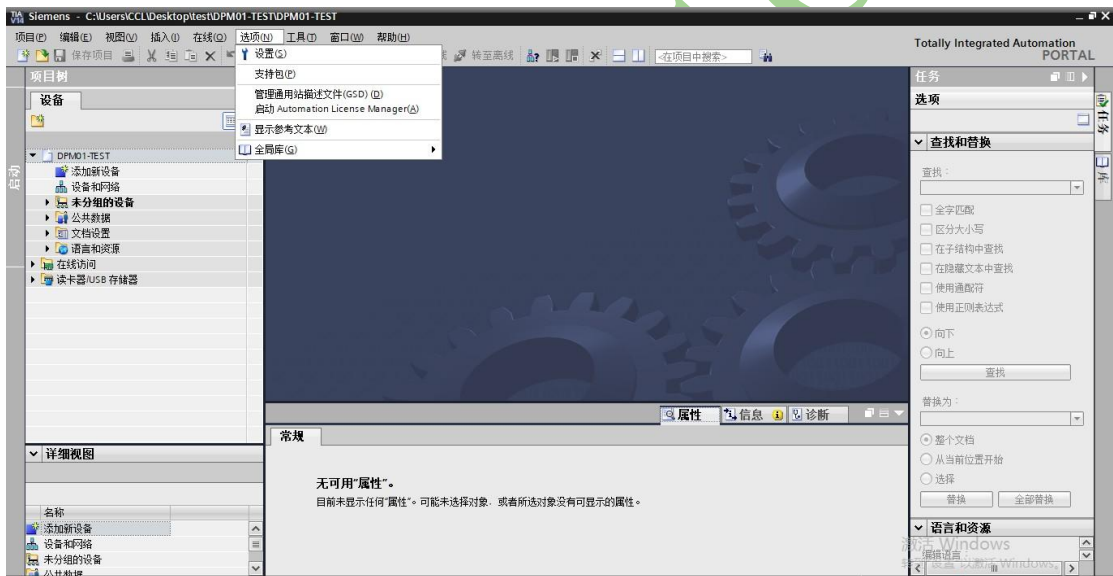

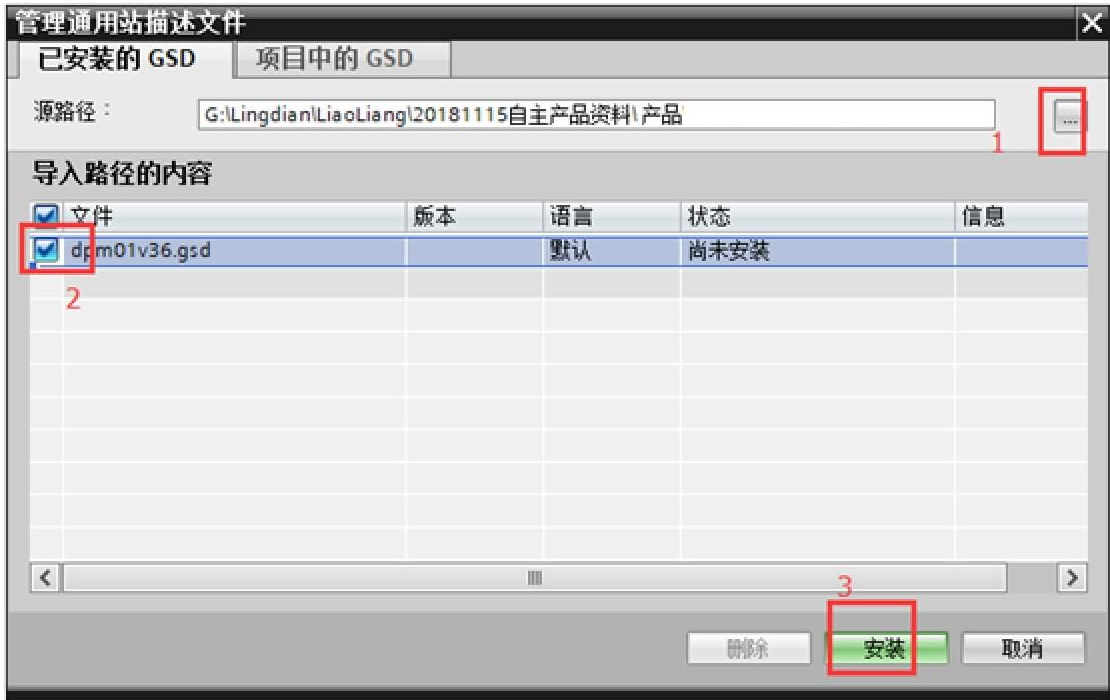

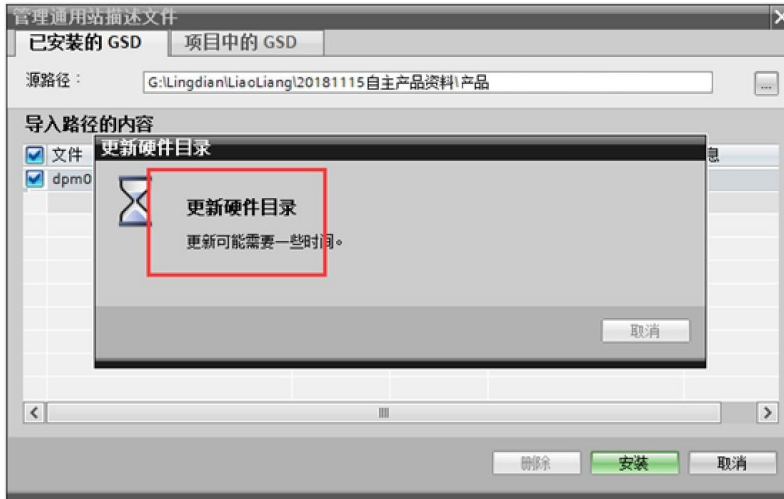

4. Under Project Number Device DPMO1-TEST, click Add New Device, select CPU 315-2 PN/DP for testing in the pop-up window, and click OK.

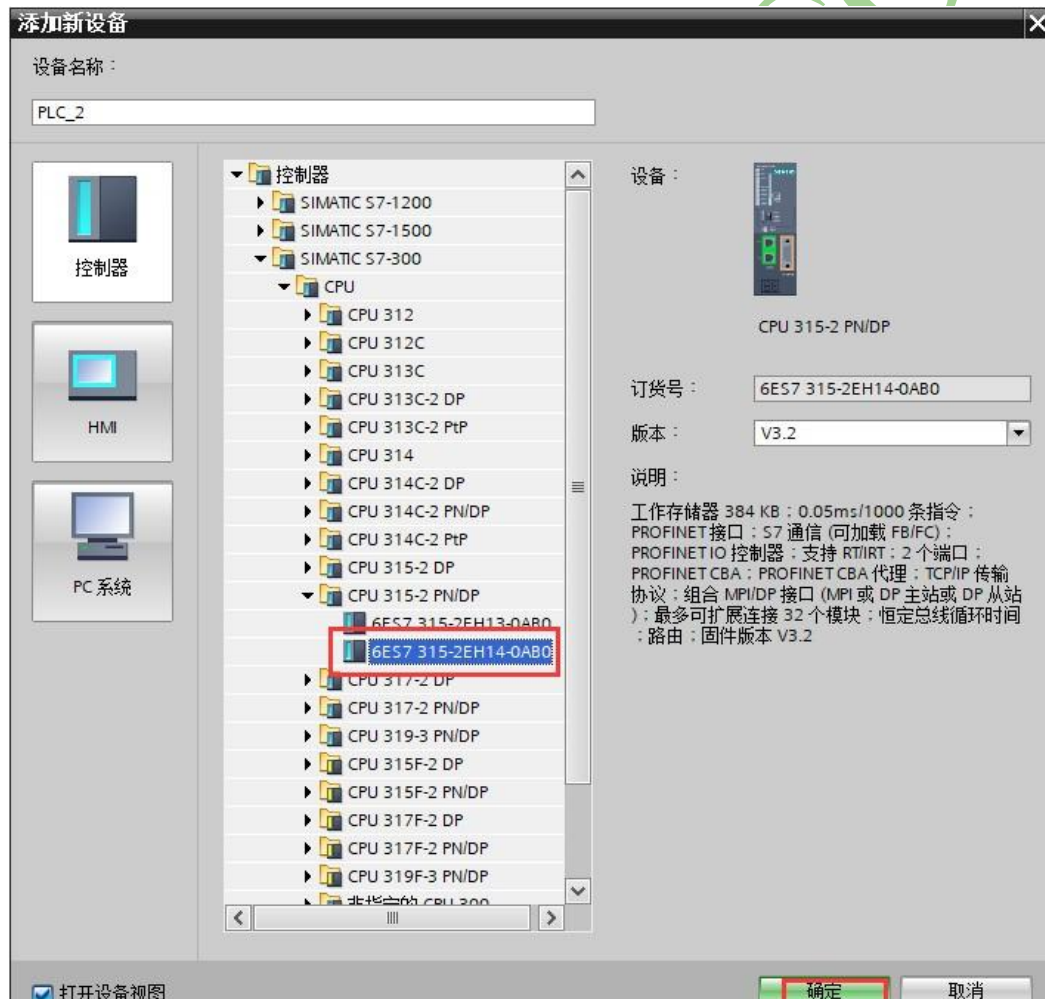

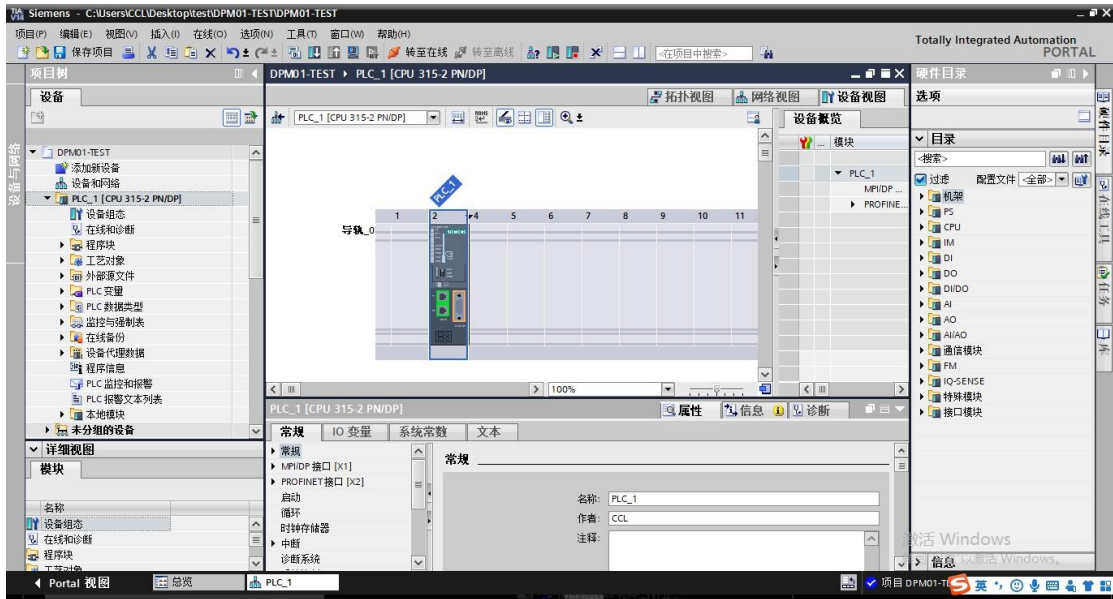

5. In the device view, select the network port of the PLC, set properties, add a new subnet, and modify the IP address.

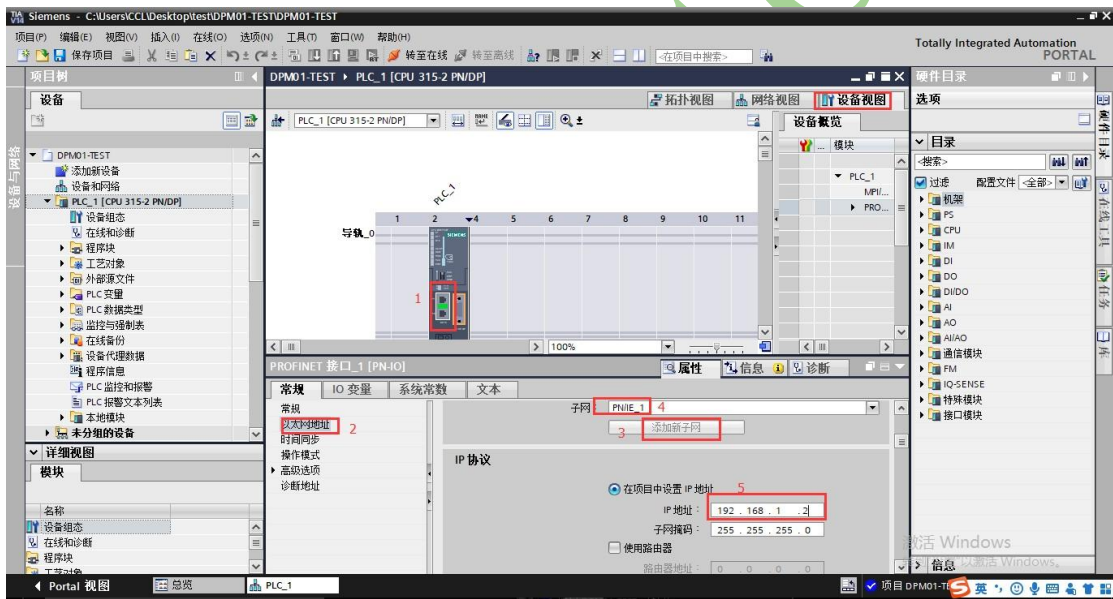

Select the MPI/DP interface of the PLC, set properties, select PROFIBUS interface type, and click to add a new subnet.

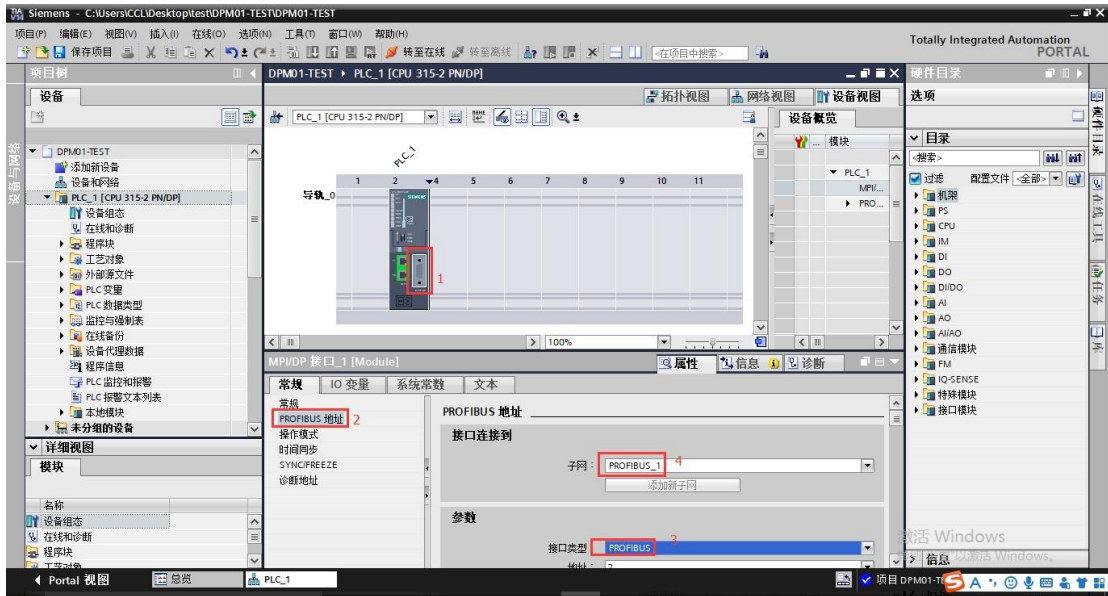

For the S7-300 series PLC, when using the gateway, it is necessary to modify the size of the process image input and output area. The default value is 128. Increase this value according to the customer's own needs. Complete the simple setup of the PLC.

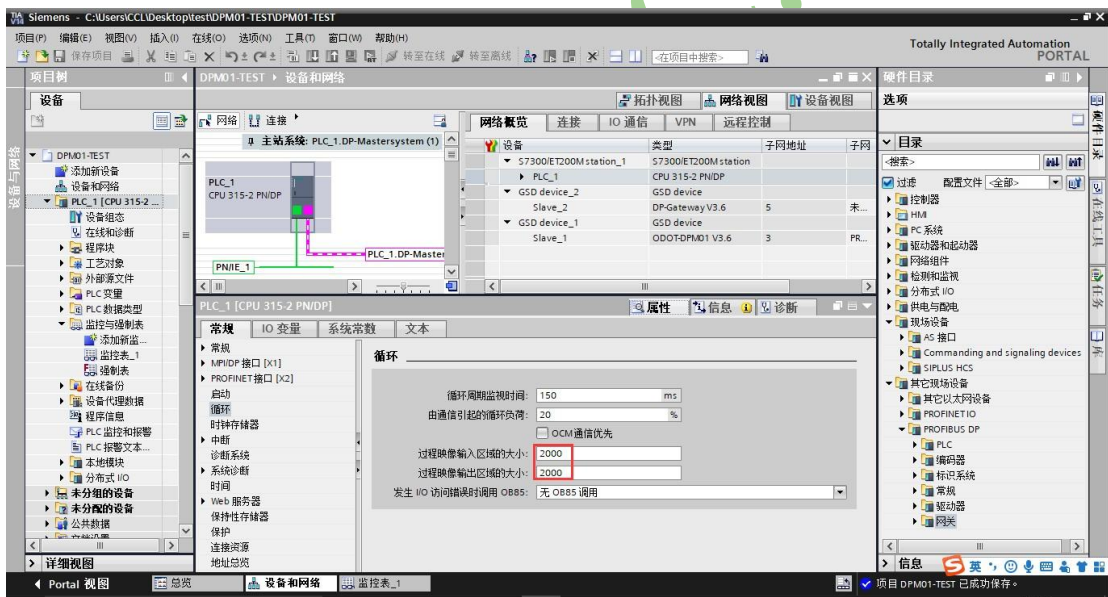

6. Click to enter the network view, find the newly installed DPM01 in the hardware directory on the right, and drag it to the network view.

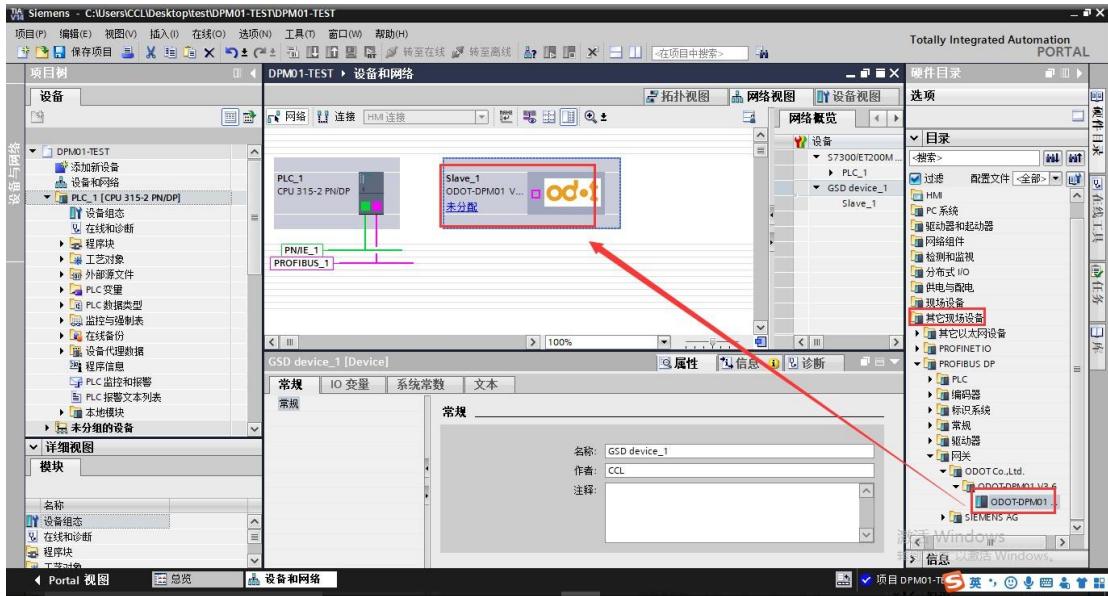

7. Select the gateway and assign a master station to it. Select the PROFIBUS-DP interface and modify the PROFIBUS parameters.

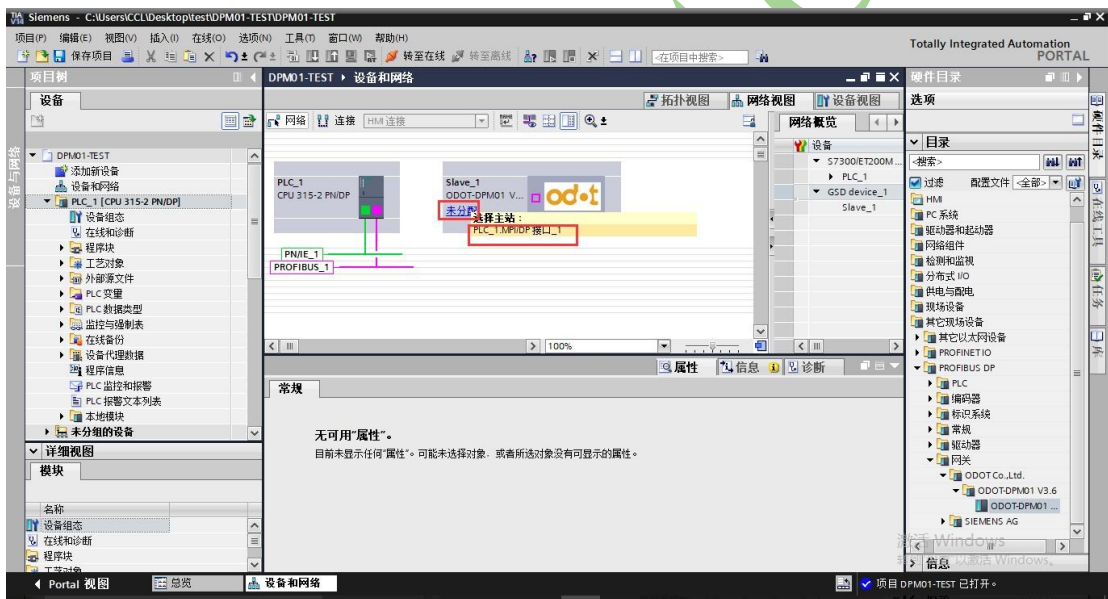

The default PROFIBUS address is 3. Check if the gateway hardware ID is dialed to 3.
(The ID filled in here should be consistent with the actual hardware dialing)

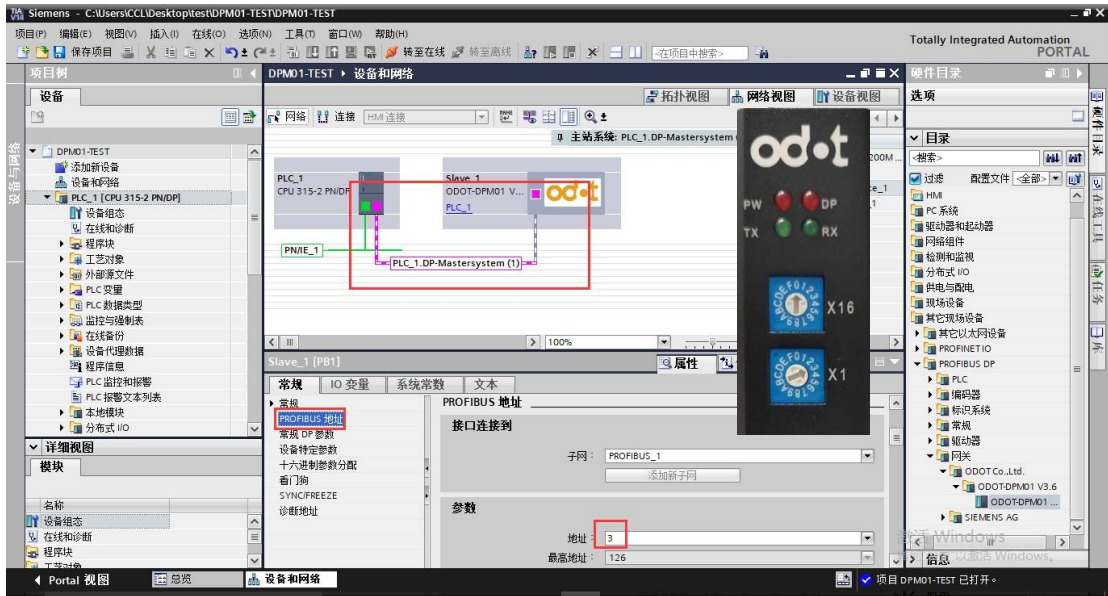

8. Click on the specific parameters of the gateway device and set the gateway MODBUS parameters (which must match the serial port parameters of the RS485 device connected to the user). If the customer cannot determine the serial port parameters, it is recommended that the customer use a USB to 485 converter and use MODBUS POLL software to directly read 485 device data through the serial port. MODBUS testing software can be downloaded from the official website or consulted with technical support.

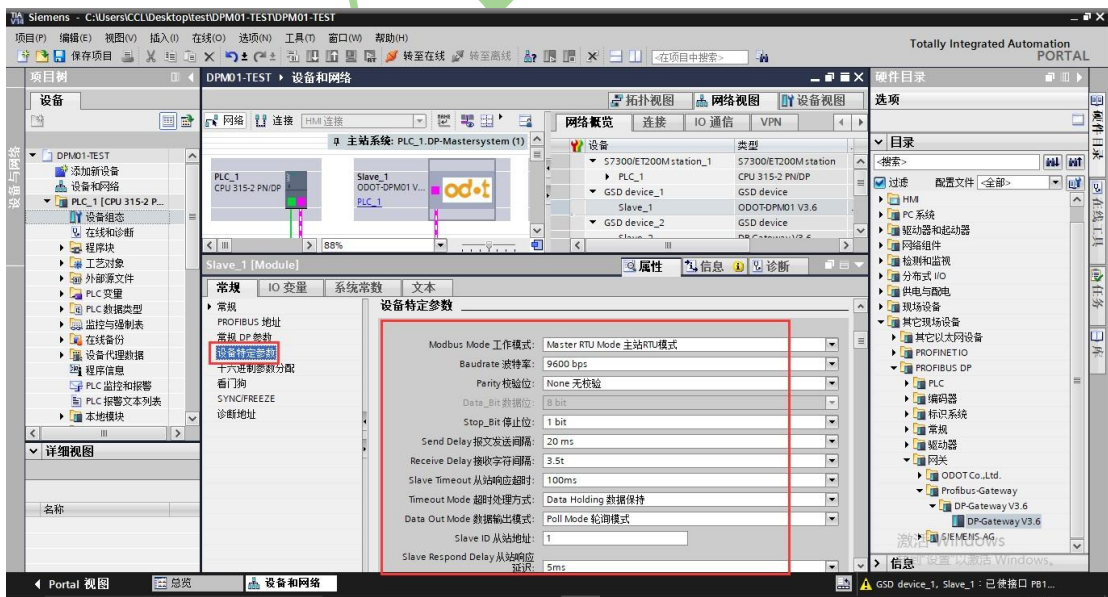

Specific meanings of parameters:

Modbus Mode 工作模式 :

Master RTU Mode 主站 RTU 模式。

Baudrate 波特率 :

Serial baud rate, optional range 1200~115200bps, default 9600bps.

Parity 校验位 :

You can choose no parity, odd parity, or even parity, with no parity by default.

Data_Bit 数据位 :

Fixed to 8-bit data.

Stop_Bit 停止位 :

1 or 2 stop bits are optional, default to 1 stop bit.

Send Delay 报文发送间隔 :

The interval time for sending Modbus commands (the delay from receiving the response message from the slave station to sending the next command) is optional from 0ms to 5000ms, with a default of 20ms.

Receive Delay 接收字符间隔 :

The frame interval detection time when receiving a message is optional from 1.5t to 200t, with a default of 3.5t (t is the time for transmitting a single character, which is related to the baud rate).

Slave Timeout 从站响应超时 :

The time it takes for the slave station to respond after the master station sends a command. 10ms~5000ms optional, default to 100ms.

Timeout Mode 超时处理方式 :

After reading data from the station timeout, the data processing method can be selected as "data reset" or "data hold". The default "data hold" mode is only valid for Modbus read commands.

Data Out Mode 数据输出模式 :

You can choose between "Polling Mode" or "Event Triggering" mode, in which Modbus periodically sends write messages. In the "event triggered" mode, write commands are only sent when the Modbus output data changes. The default is "polling mode", which is only valid for Modbus write commands.

Slave ID :

This parameter is invalid for the Master mode.

Slave Respond Delay 从站响应延迟：

This parameter is invalid for the Master mode.

9. Double click on the gateway to enter the gateway MODBUS master mode data read and write command configuration.

The Master station module starts with M: and can only be used in Modbus Master station mode.

Note: When the MODBUS side slave equipment needs to use function code 05 (to write a single coil), please use M: Write singer bit (0xxxx). When the MODBUS side slave equipment needs to use function code 06 (to write a single register), please use M: Write singer word (4xxxx).

10. In order to facilitate monitoring of the communication status of 485 devices on site, a diagnostic module can be added. **The master station diagnostic module is a selectable module.**

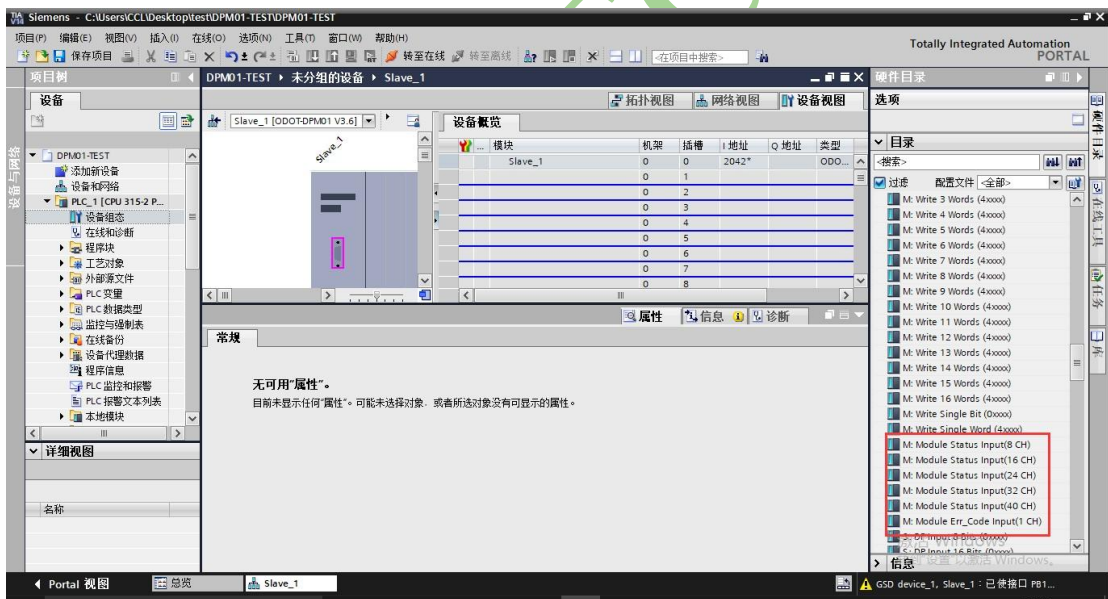

The main station diagnostic module is divided into two types: "Slot Status Input" and "Slot Error Code Input Module ErrCode Input". Two types of modules can only be plugged in at most one each. And insert it into the slot at the front position. The status module can monitor the working status of each data slot. When a data slot fails, the corresponding status bit is set to 1, and it automatically resets to zero after the fault is restored.

When a data slot malfunctions, the error code module can display the serial number and specific error code of the erroneous data slot. Users can determine the cause of the malfunction based on the error code and take corresponding adjustment methods. Please refer to the "Error Code Table" for a detailed description.

The error code module can only display the fault status of one slot. When multiple slots fail simultaneously, the error code module will display the fault status of the slot with the lowest serial number in the error slot. The detailed error codes are shown in the table below

Modbus Master Error Code Table

Error Code	Fault description	Troubleshooting method
0x00	Working properly	N/A
0x01	Illegal function code	The device does not support the current function code, please refer to the slave manual to select the corresponding function code module
0x02	Illegal data address	If the device data exceeds its address range, refer to the slave manual to modify the data starting address or data length
0x03	Illegal data value	Data length error, data length beyond the Max. allowed value 125(Word) or 2000(Bit), modify the length
0x04	Slave device error	Check the status of the slave device
0x06	Slave device busy	Check the status of the slave device
0x07	parity error	Check parity, baud rate, stop bit, and hardware connection status
0x09	CRC verification error	Slave response message CRC calculation error, check the working status of the slave

0x0B	Slave device response timeout	Increase the timeout time, check the hardware connection status, and view communication parameter settings such as baud rate
0x0E	Response message length error	Increase the receive character spacing
0x0F	Write slave device response error	Check the hardware connection state

11. Add input status module, error code module, read MODBUS Zone 0/Zone 1/Zone 3/Zone 4 data, and write Zone 0/Zone 4 data. The default parameter for all commands is slave ID=1. The starting address is 0. Therefore, for the actual 485 equipment on site, corresponding read and write commands should be selected, and the slave station ID and start address should be modified.

This document provides a simple demonstration. The first four commands use default values, changing the starting address of the fifth command to 20 and the starting address of the sixth command to 30. Simulate on-site 485 devices using Modbus Slave software.

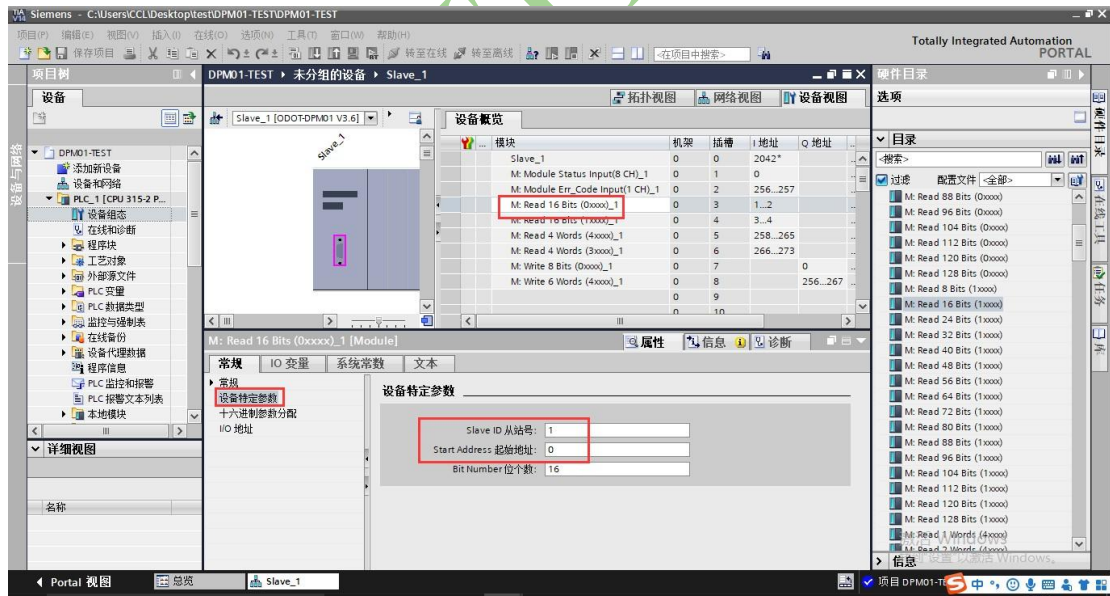

12. After setting up, save, compile, and download the project.

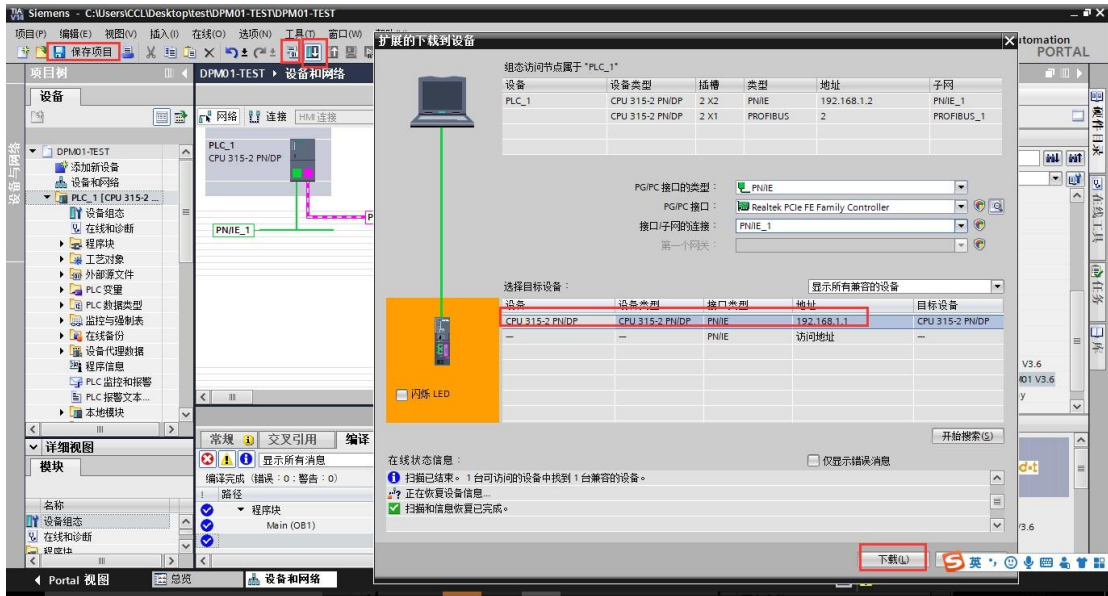

13. After downloading, open the monitoring table, fill in the command address corresponding to the gateway, open Modbus Slave software, simulate the slave station, and set the serial port parameters to 9600/N/8/1.

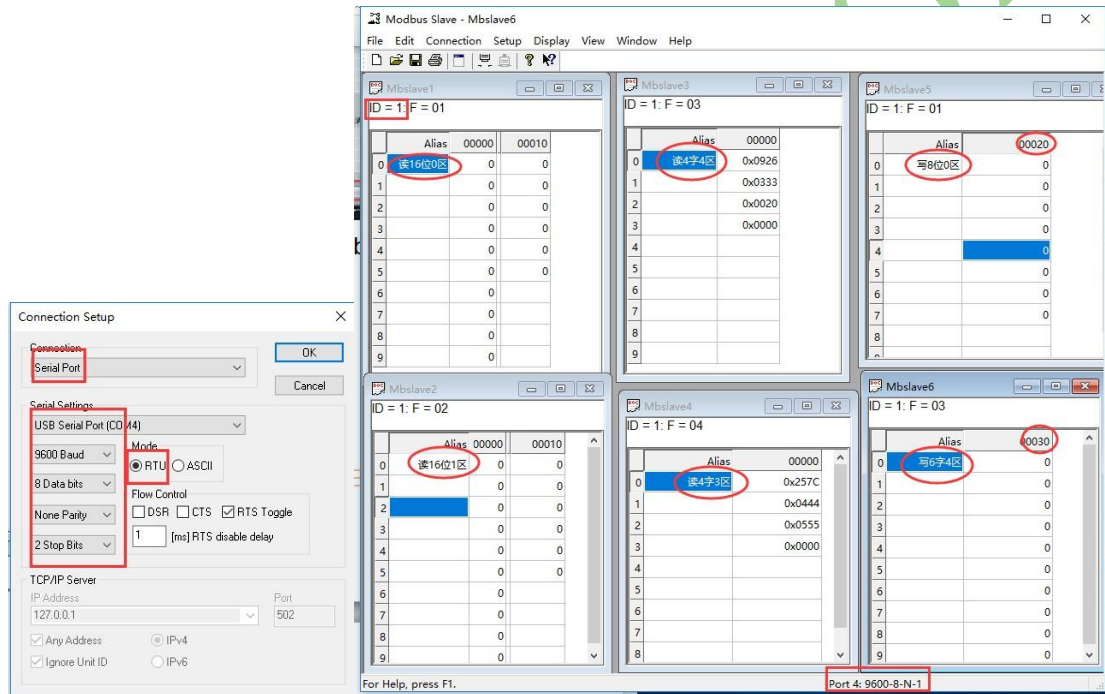
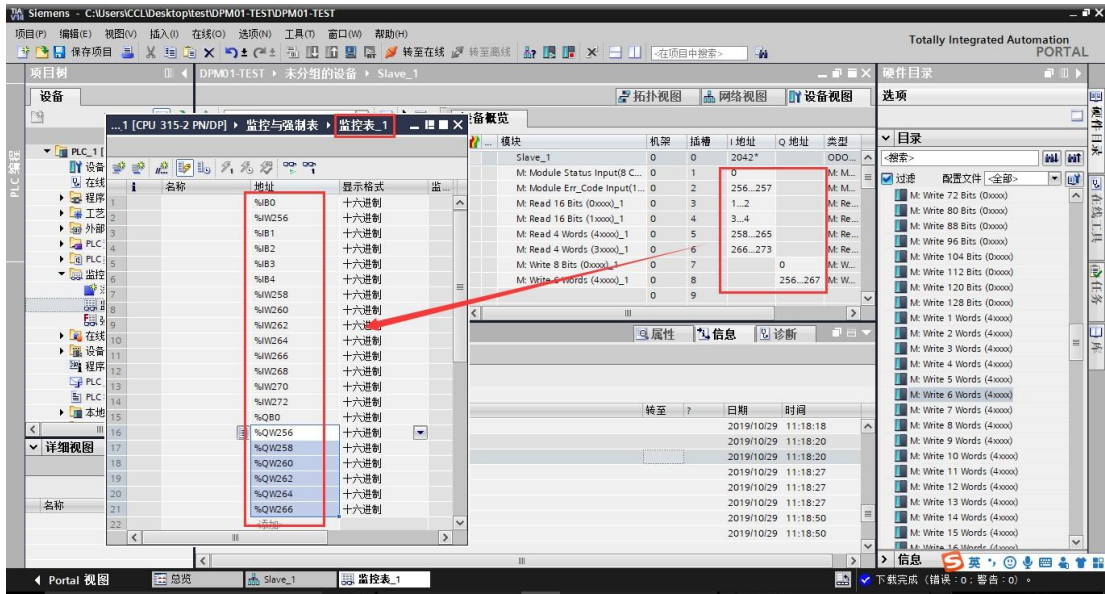

14. Turn the TIA project online, click the online monitoring button on the monitoring table, and you can check that the PLC collected data is consistent with the 485 serial port side data. When writing data, fill in the modified value column with the value to be written, click . Immediately modify the ownership system at once, and the 485 side will receive data issued by the PLC. At this point, the gateway is in a normal working state, and both the input status address value and the error code address value display 0.

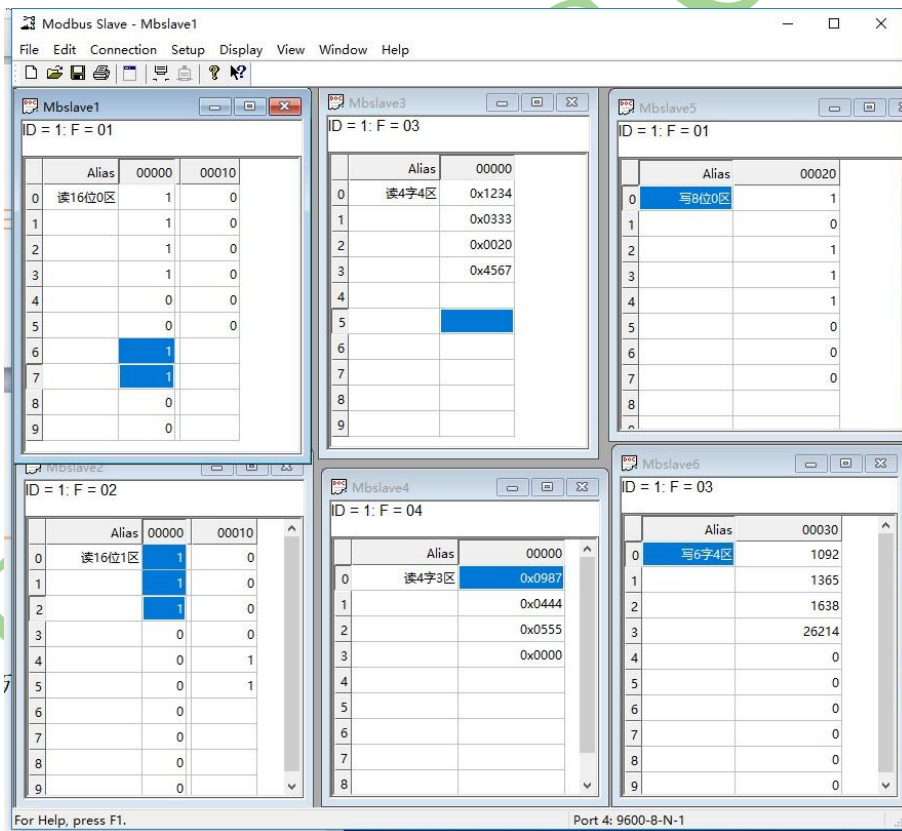
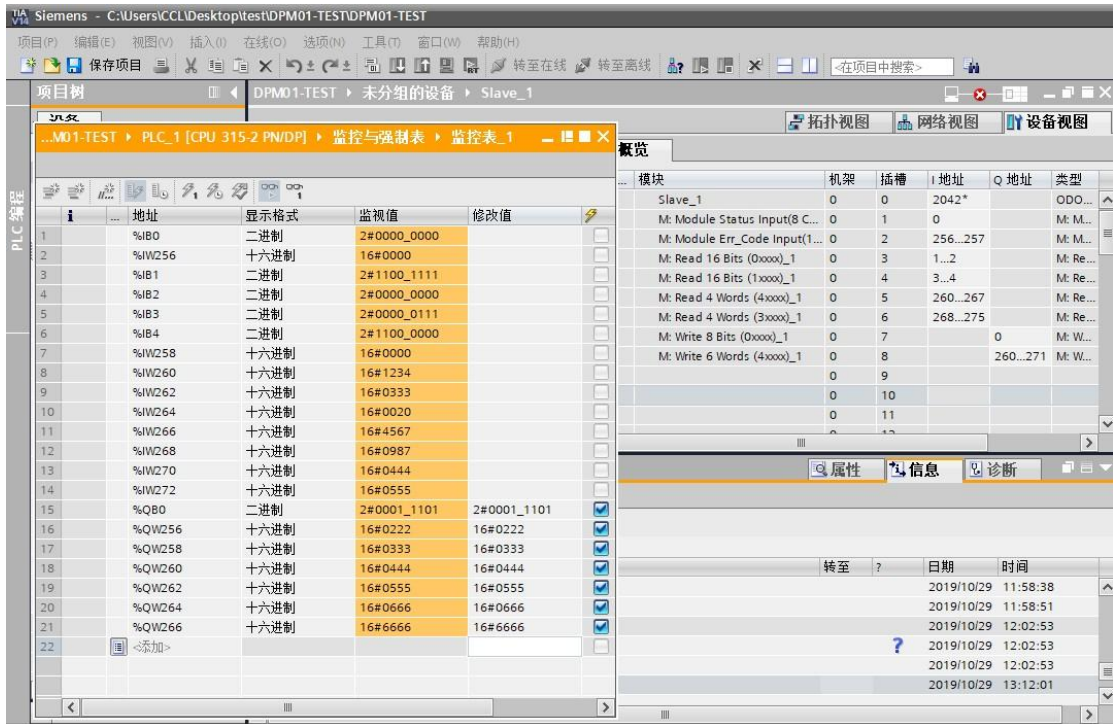

15. When the input status address value and error code address value are not 0, analyze the fault location based on the actual displayed value and the error code, as shown in the following figure: % IB0=2 # 00100000,% IW256=16 # 0602,

indicating that the sixth read and write command in the gateway configuration is faulty and has an invalid data address.

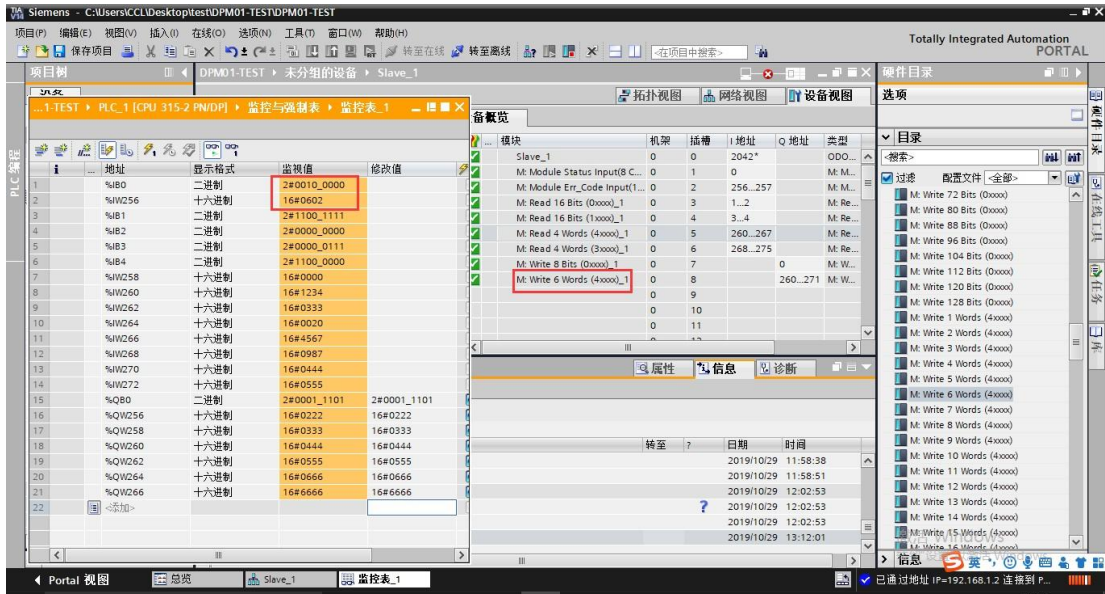

5.2 Modbus RTU Slave Mode

1.Modbus Slave Mode Data Address Table

Data area	Effective address range
Zone 0 (0XXXX)	0~1951
Zone 1 (1XXXX)	0~1951
Zone 3 (3XXXX)	0~121
Zone 4 (4XXXX)	0~121

2→8 Refer to 4.1(Master mode)的 1→7。

9. Click on the specific parameters of the gateway device and set the gateway MODBUS parameters (which must match the serial port parameters of the RS485 device connected to the user). The gateway working mode selects the slave RTU mode. Gateway 485 side serves as a slave station, with slave station ID=4 and serial port parameters using default values.

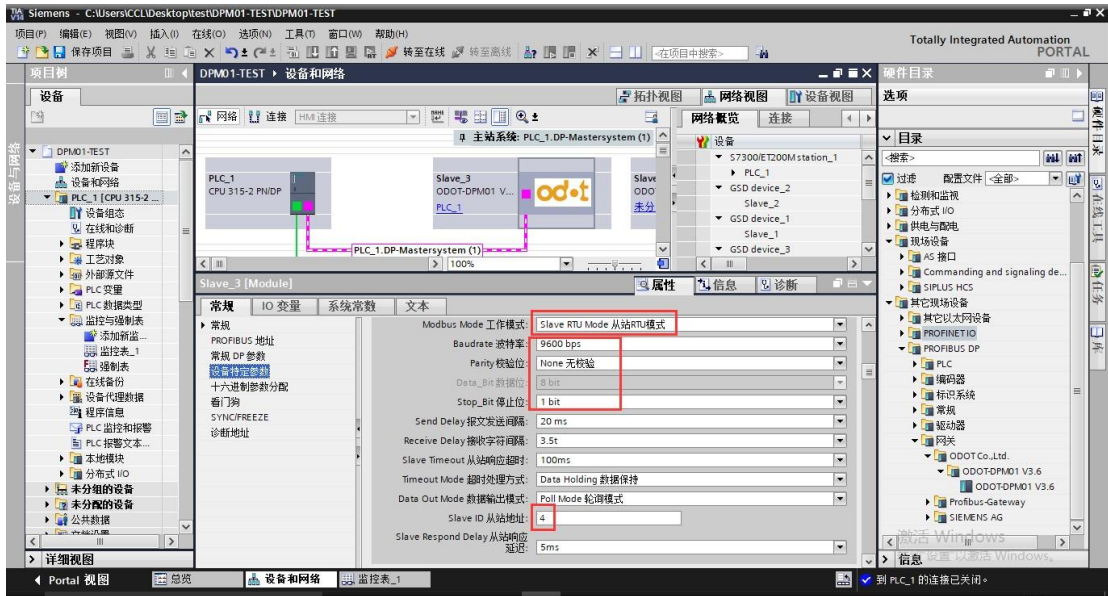

Modbus Mode 工作模式:

Slave Mode 从站模式。

Baudrate 波特率 :

Serial baud rate, optional range 1200~115200bps, default 9600bps.

Parity 校验位 :

You can choose no parity, odd parity, or even parity, with no parity by default.

Data_Bit 数据位 :

Fixed to 8-bit data.

Stop_Bit 停止位 :

1 or 2 stop bits are optional, default to 1 stop bit.

Send Delay 报文发送间隔 :

This parameter is invalid for the slave mode.

Receive Delay 接收字符间隔 :

The frame interval detection time when receiving a message is optional from 1.5t to 200t, with a default of 3.5t (t is the time for transmitting a single character, which is related to the baud rate).

Slave Timeout 从站响应超时 :

This parameter is invalid for the slave mode.

Timeout Mode 超时处理方式 :

This parameter is invalid for the slave mode.

Data Out Mode 数据输出模式 :

This parameter is invalid for the slave mode.

Slave ID :

Slave ID number, valid range is 1-247, default value is 1.

Slave Respond Delay 从站响应延迟 :

The response delay time of the slave station is when the slave station receives a request message from the master station, processes the data, delays for a certain length of time, and then replies to the data message. 0ms~2000ms optional, default 5ms.

10. Double click the gateway icon to enter the device view. The slave module read and write commands starting with S: can be found in the hardware directory on the right.

Contains input/output commands and Modbus status input commands.

The Modbus slave status module can only be used in slave mode, and the DP side can read the slave status to determine the working status of the Modbus slave. When the slave station is working normally, the error code is 0. When an error occurs at the slave station, the error code will indicate the cause of the error. The error codes are shown in the table below:

Modbus Slave Error Code Table

Error Code	Fault description	Troubleshooting method
0x00	Working properly	N/A
0x01	Illegal function code	The device does not support the current function code, please refer to the slave manual to select the corresponding function code module
0x02	Illegal data address	If the device data exceeds its address range, refer to the slave manual to modify the data starting address or data length
0x03	Illegal data value	Data length error, data length beyond the Max. allowed value 125(Word) or 2000(Bit), modify the length
0x07	parity error	Check parity, baud rate, stop bit, and hardware connection status

0x09	CRC verification error	Slave response message CRC calculation error, check the working status of the slave
0x0E	Response message length error	Increase the receive character spacing

The Modbus state input command is not mandatory when testing applications.

11. Add an input status module, DP outputs data from Zone 0/Zone 1/Zone 3/Zone 4, and DP inputs data from Zone 0/Zone 4. The default parameter for all commands is a starting byte/word address of 0. So, for the actual 485 master station equipment on site, set the corresponding starting byte/word address to communicate data with the DP master station.

This document provides a simple demonstration by changing the starting byte address of the third command to 1, the starting word address of the sixth command to 7, and using default values for other commands. Simulate the on-site 485 master station equipment using Modbus Poll software.

Note: The starting address for bit reading and writing is a byte address

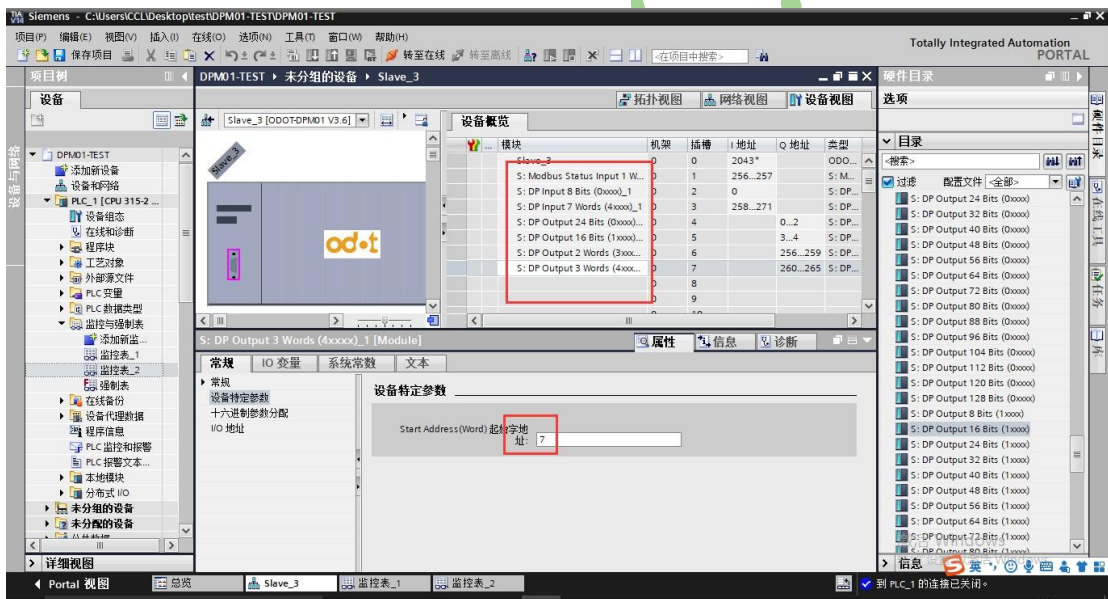

12. After setting up, save, compile, and download the project.

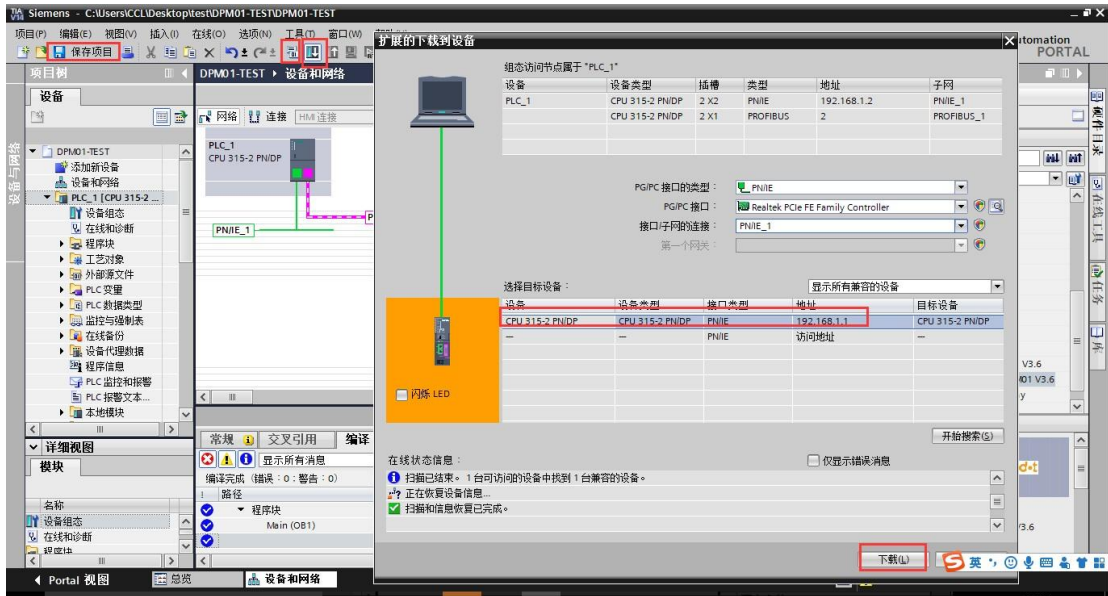

- After downloading, open the monitoring table, fill in the command address corresponding to the gateway, open Modbus Poll software, simulate the main station, establish a connection, default RTU protocol, serial port parameters 9600/N/8/1.

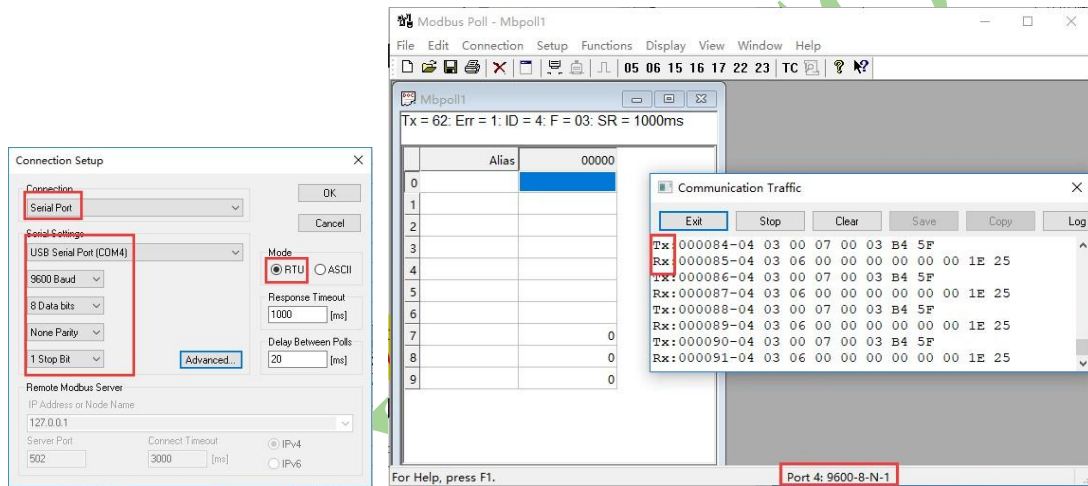
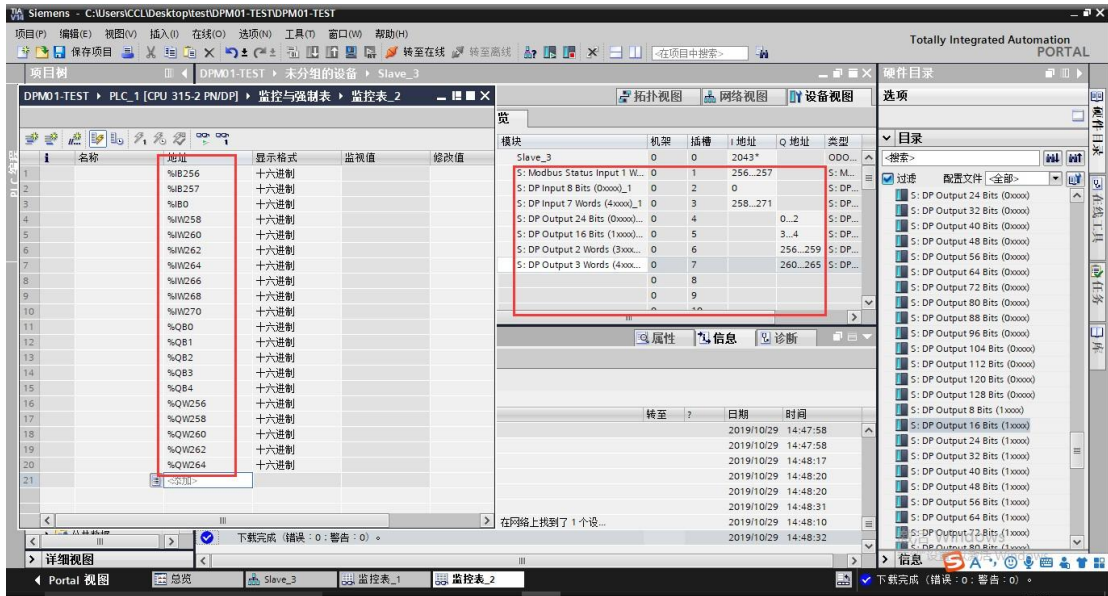

From the Modbus poll message, it can be seen that the communication connection has been established.

14. Transfer the TIA project online and click on the monitor table  The online monitoring button allows you to view that the data collected by the PLC is consistent with the serial port data of the 485 main station. When outputting data, fill in the

modified value column with the value to be output, click  By modifying the ownership system at once, the 485 side of the main station will receive data issued by the PLC.

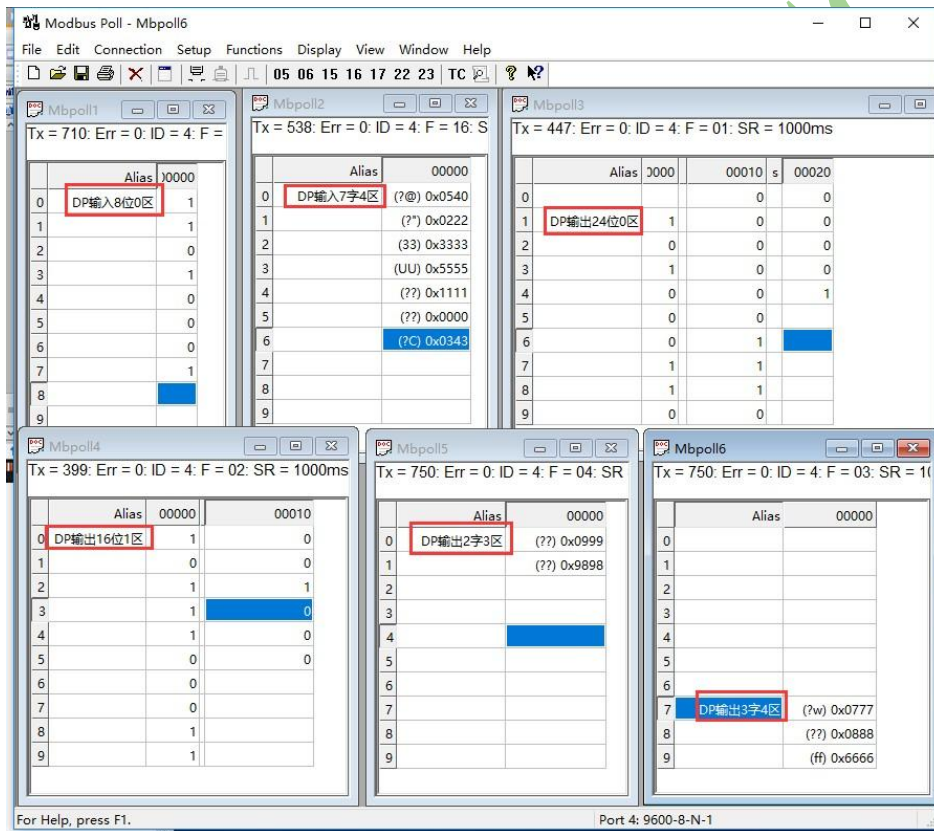
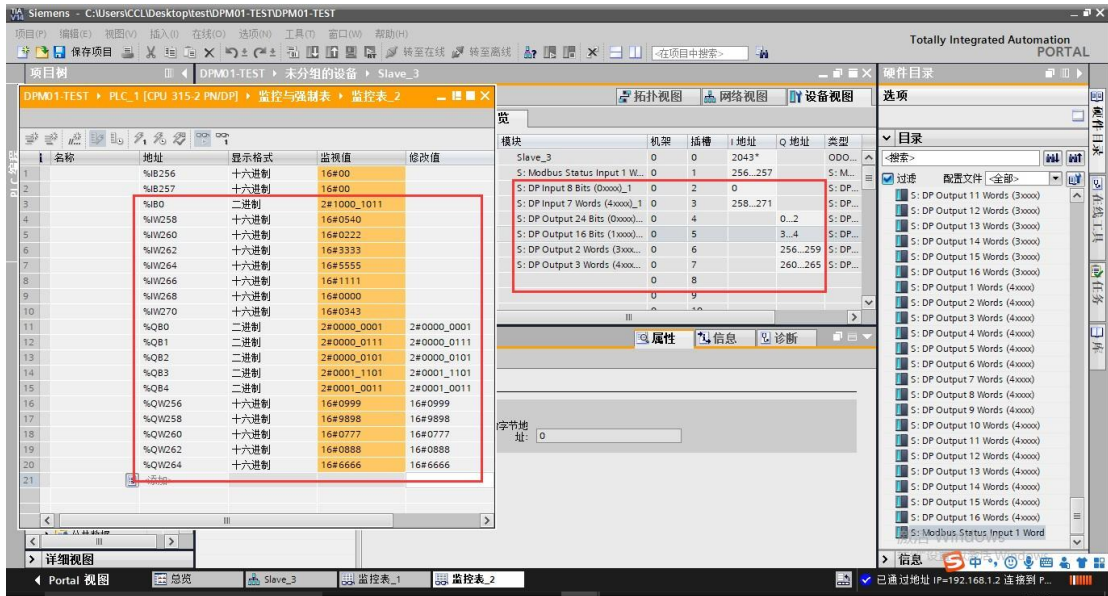

At this time, the gateway is in a normal working state, and the input status address value shows 0.

5.3 Modbus ASCII Master Mode

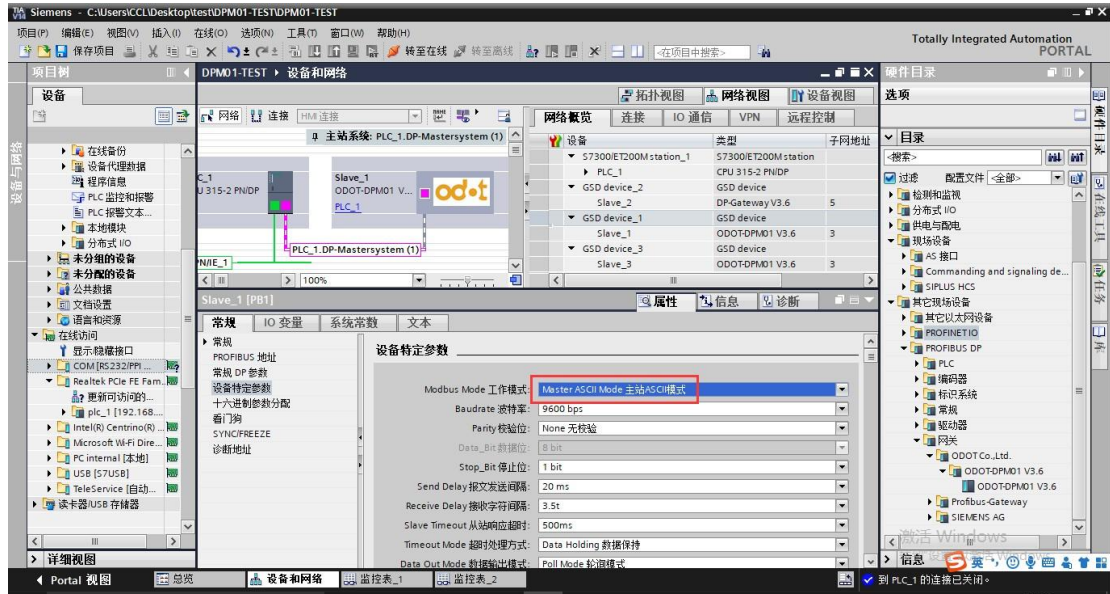

Refer to 4.1 MODBUS RTU master station mode configuration.

Just change the gateway working mode to: **Master Station ASCII mode**. Save compilation download.

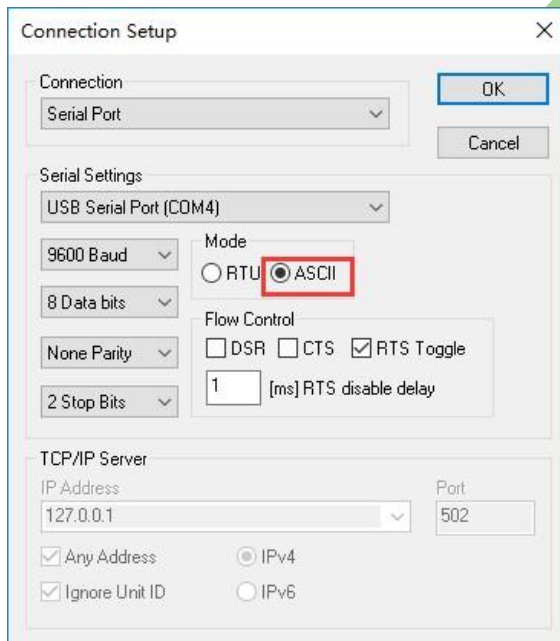

When using Modbus Slave software for testing, choose the ASCII protocol when establishing a connection.



Transfer the TIA project online and click on the monitoring table . The online monitoring button allows you to view that the data collected by the PLC is consistent with the serial port data of the 485 main station. When outputting data, fill in the modified value column with the value to be output, click . Immediately modify the ownership at once, and the 485 side of the main station will receive data issued by the

PLC.

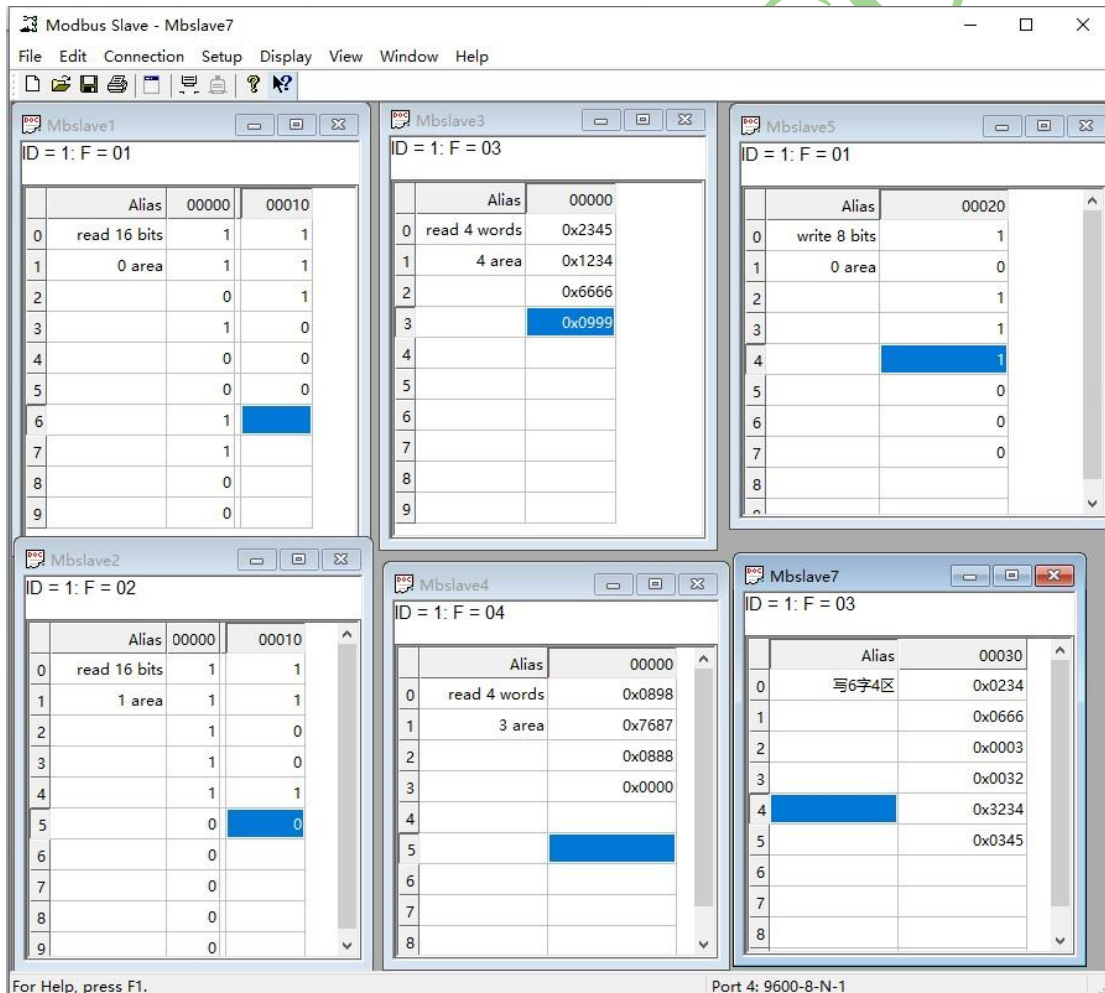
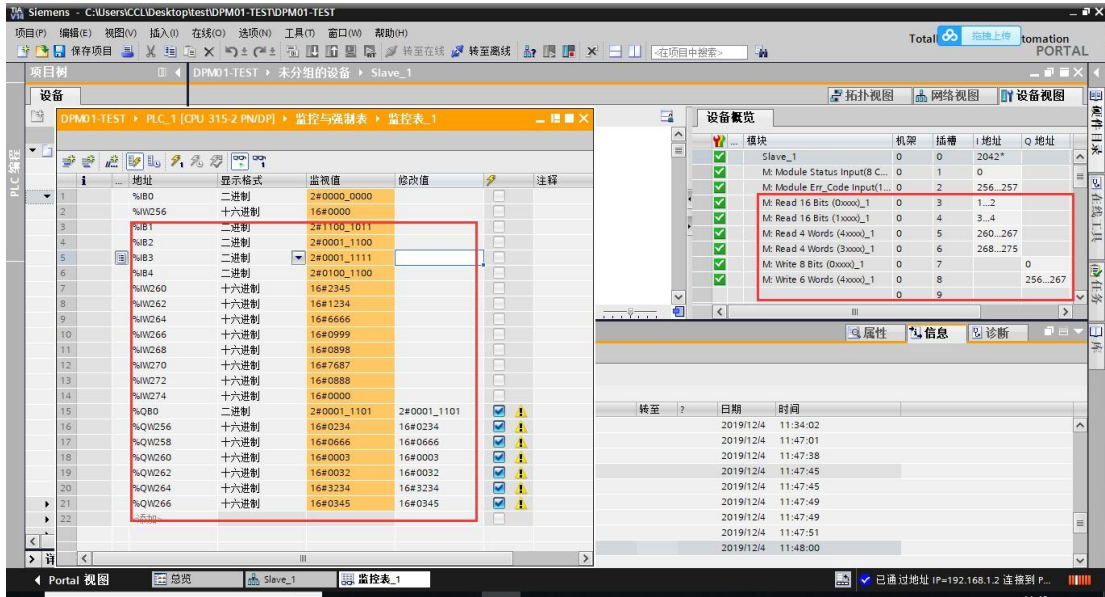

5.4 Modbus ASCII Slave Mode

Refer to 4.2 MODBUS RTU slave mode configuration

Just change the gateway working mode to: **Slave ASCII mode. Save compilation download.**

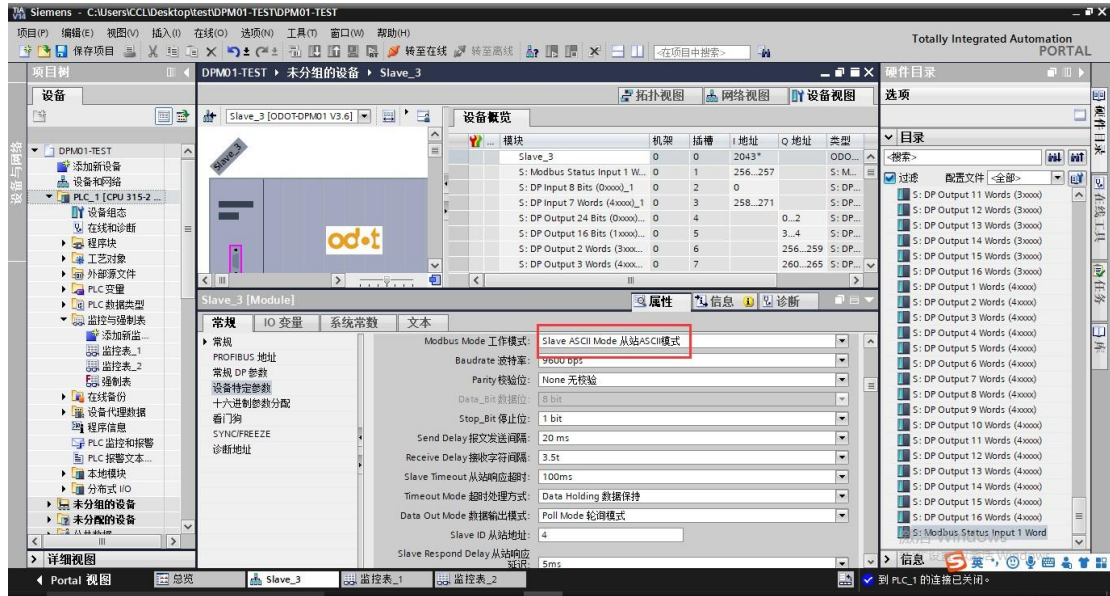

When using Modbus Poll software for testing, choose the ASCII protocol when establishing a connection.

Transfer the TIA project online and click on the monitoring table

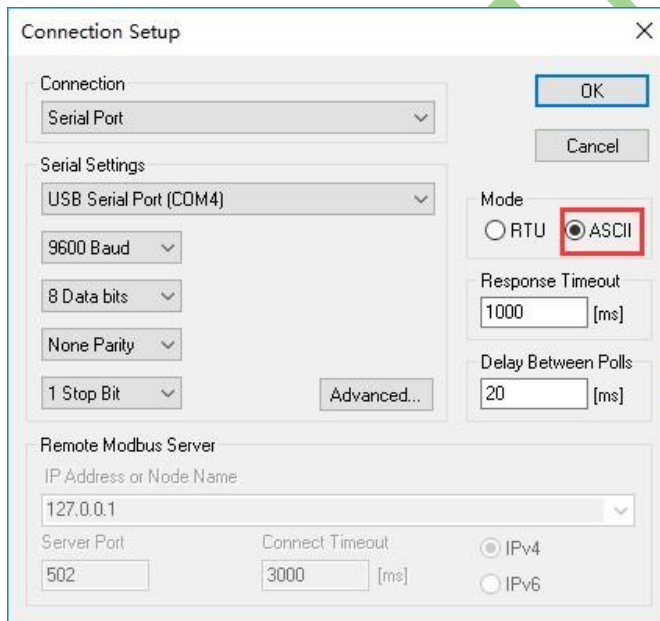

The online monitoring button allows you to view that the data collected by the PLC is consistent with the serial port data of the 485 main station. When outputting data, fill in the modified

value column with the value to be output, click . Immediately modify the ownership at once, and the 485 side of the main station will receive data issued by the PLC.

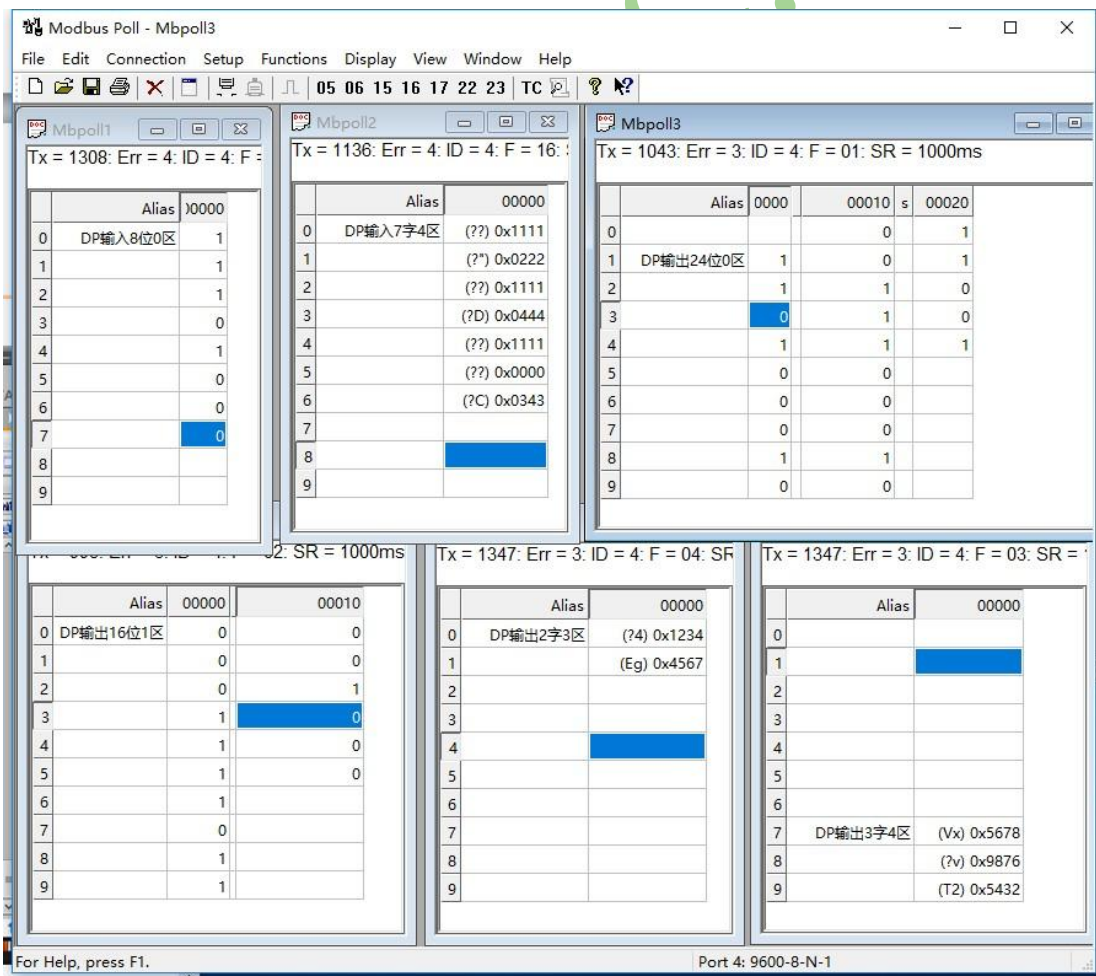
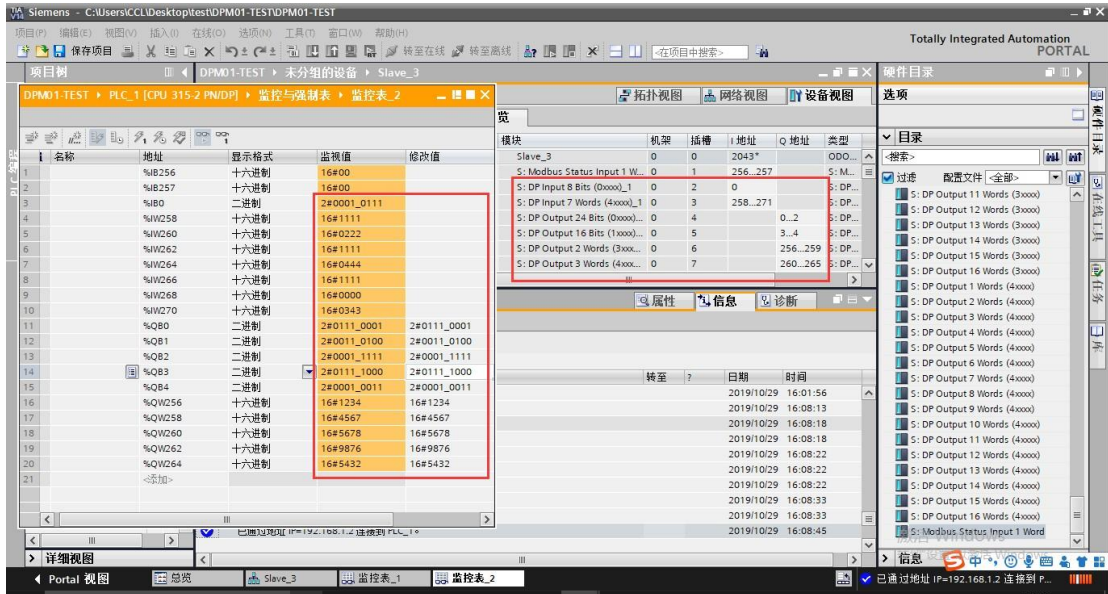

6 Test application in Beckhoff TwinCAT 2

1. Power on all hardware cables and connect the CX5120 to the monitor. Open the corresponding Beckhoff software System Manager, PLC Control interface.

Open the System Manager interface, click Actives--Set/Reset TwinCAT to Config Mode, PLC enters the configuration mode. Right-click I/O Devices—Scan Devices, In the dialog box that pops up (not all device types can be discovered automatically), click OK, in the dialog box that appears, select the I/O device type, click OK, in the pop-up dialog box (Scan Boxes), click Yes, in the dialog box that pops up (Activate Free Run), click NO. It could automatically scan all IO modules attached to the CX5120. See diagram below.

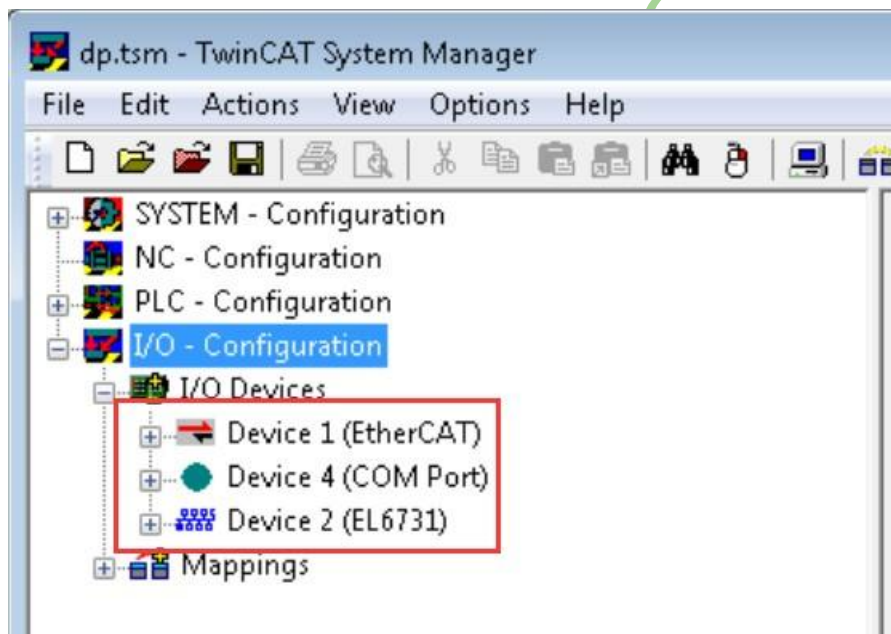

Right-click Device 2 (EL6731)—Append Box, in the dialog box that pops up, select Generic Profibus Box (GSD)—OK, locate the file where the GSD file of DPM01 resides, click to open, the gateway is automatically attached to the EL6731 module.

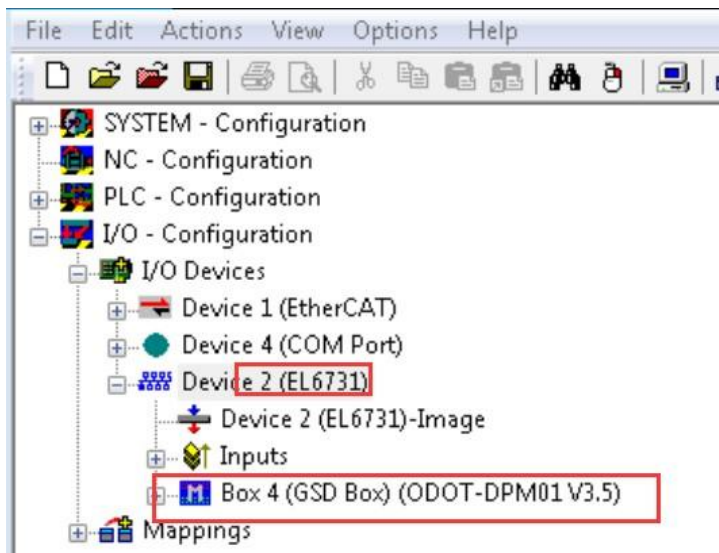
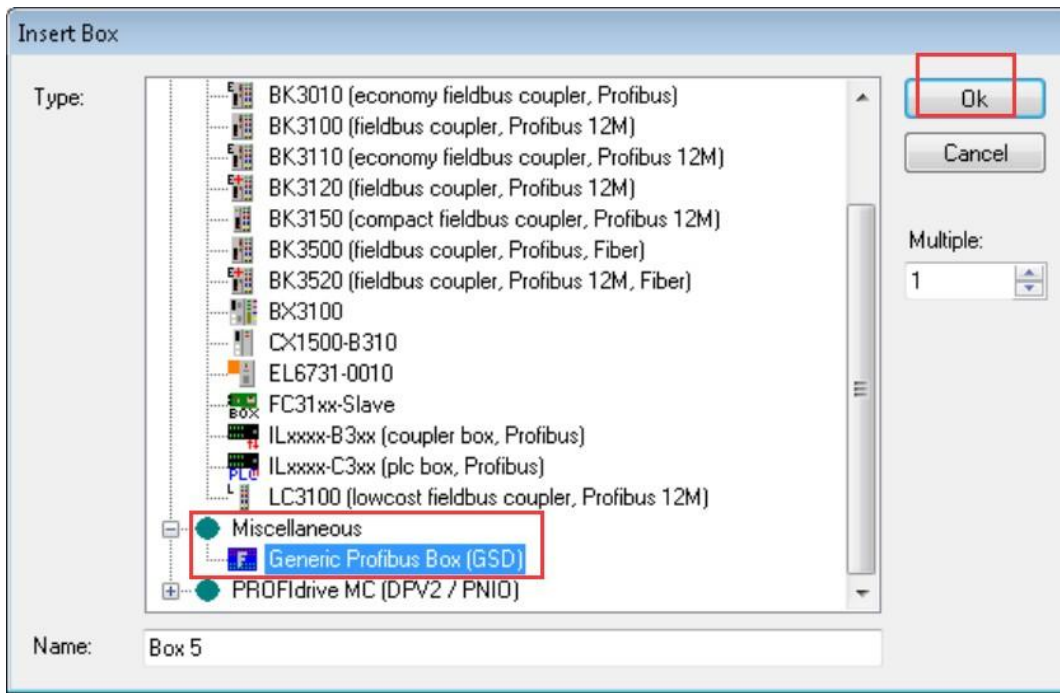

Select the DPM01. On the right side of PrmData, set the serial port parameters of the gateway. Gateway working mode select Slave mode, that is, the gateway 485 side is the Slave of 485.

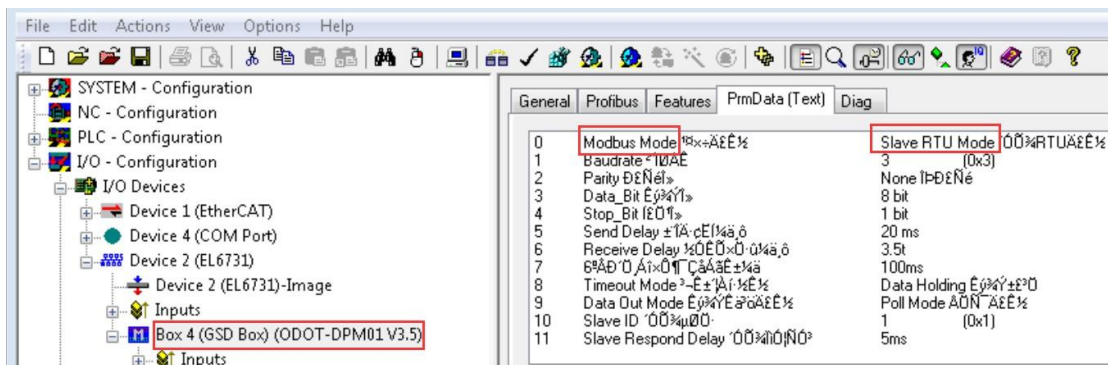

Right-click DPM01—Append Module, in the dialog box that appears, select Read and Write Commands.

Because the working mode of the gateway is Slave, select the read and write commands with S: in the front of. After the command is added, it will be attached to the lower side of the gateway DPM01.

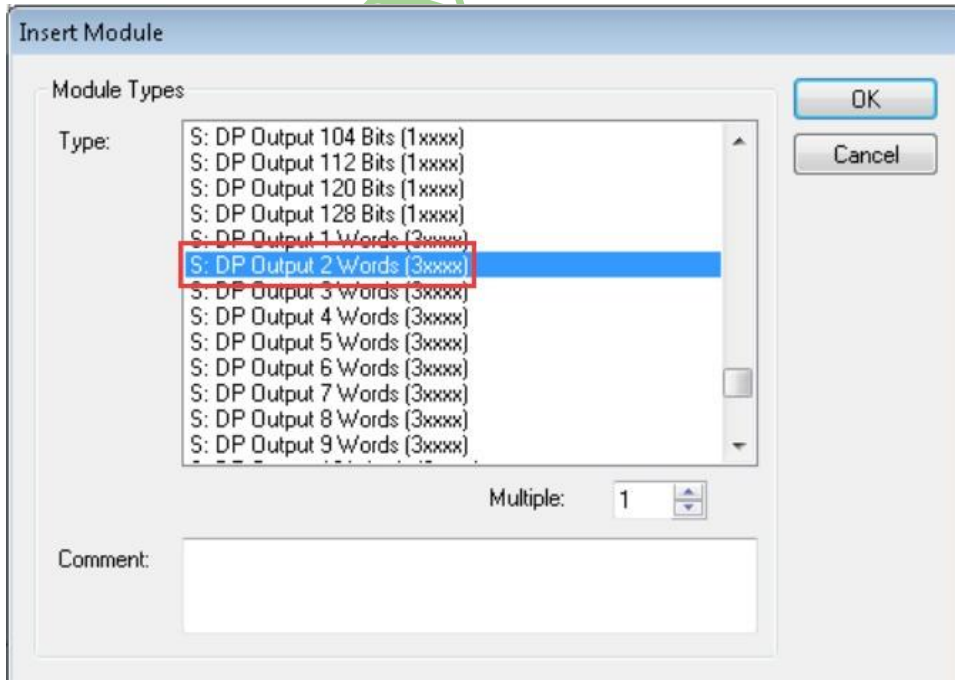
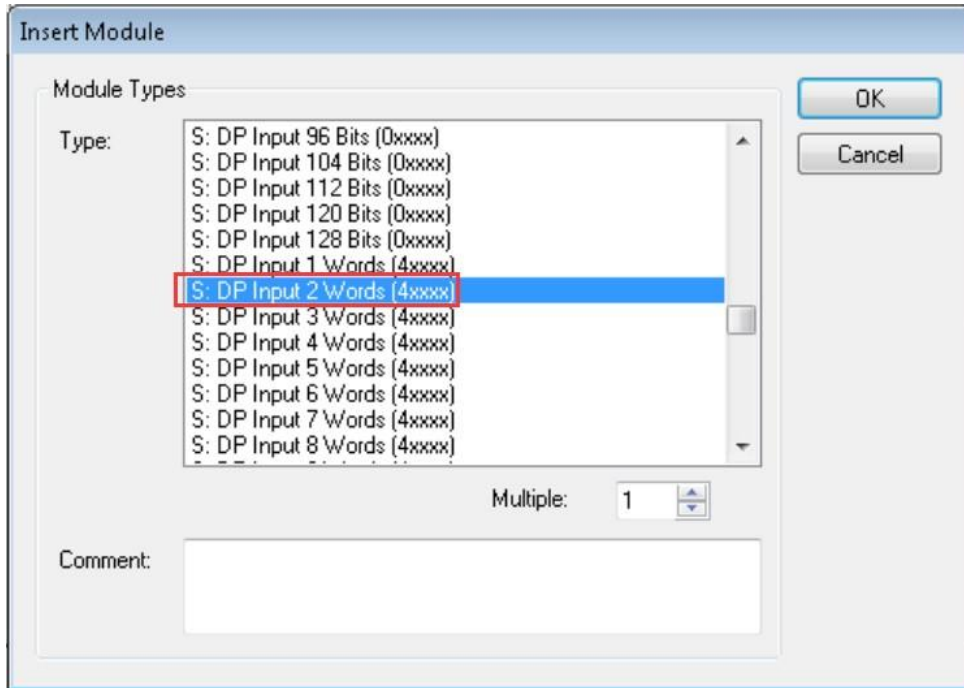

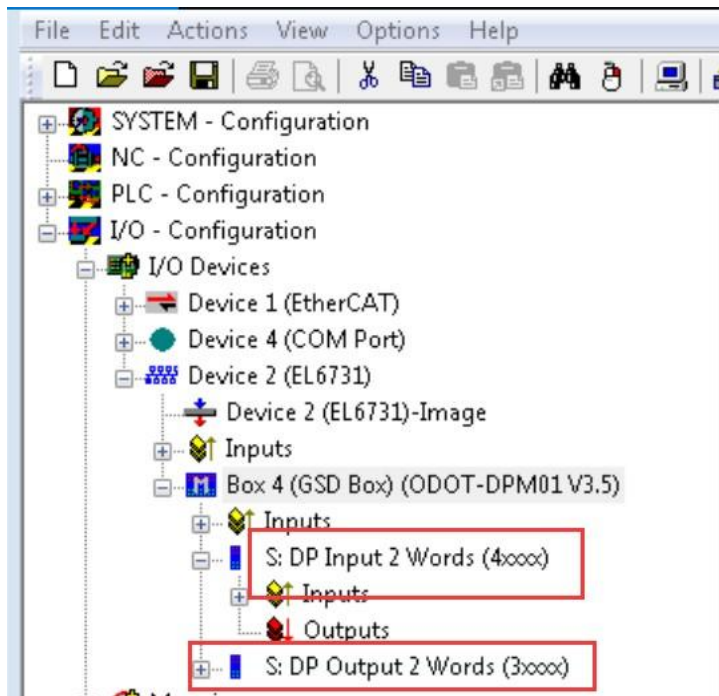

Select the added command, and set the corresponding start address of 485 device in PrmData on the right, and the start address of both test commands is 0.

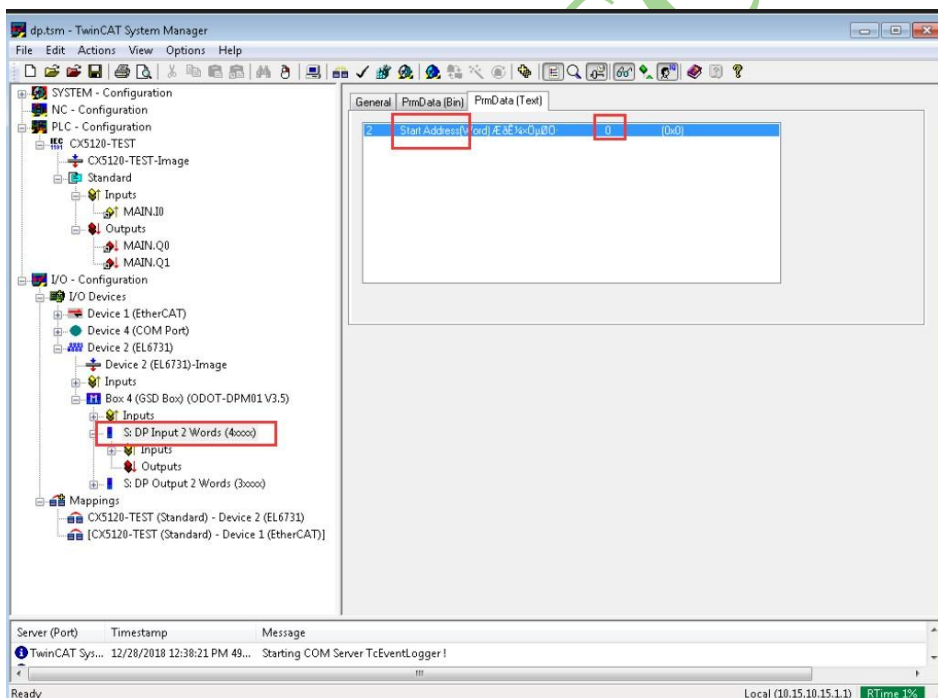

2. Open the PLC Control interface, create a new project, default options, and click OK.

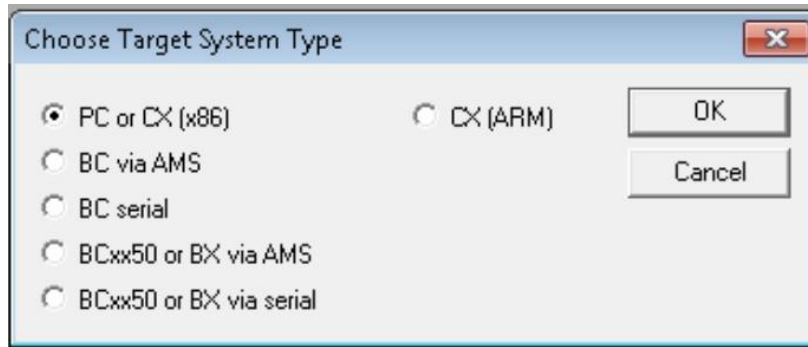

Edit a simple program, define variables, and the program logic is Q0 alternately assigned 85 or 170, Q1=I1.

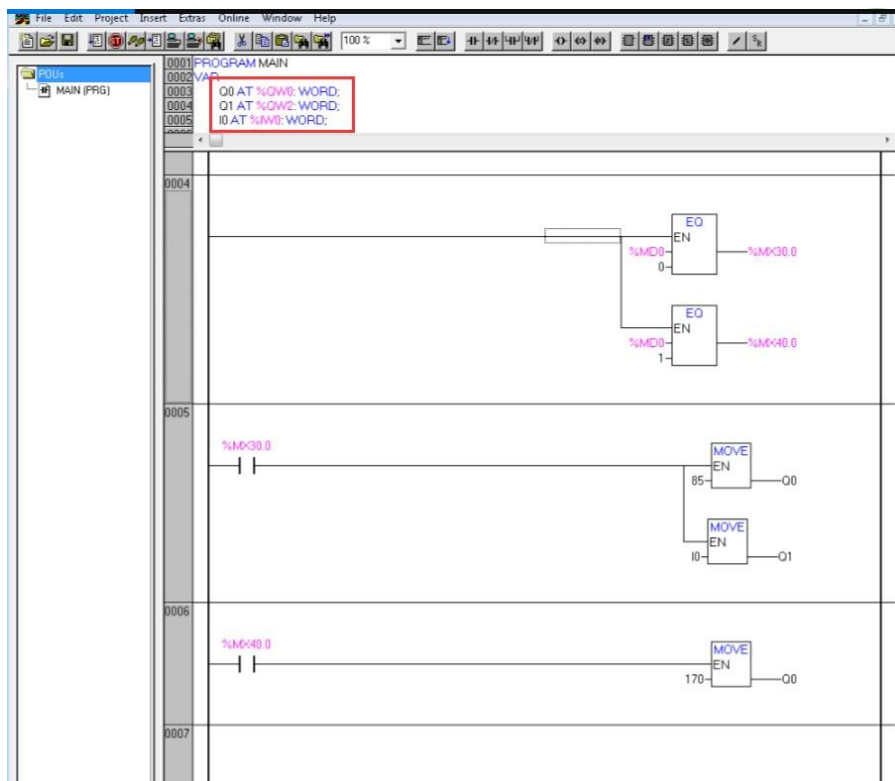

Compile all the programs, and a file CX5120-TEST.tpy will appear in the program save directory.



3. Return the System Manager interface, right-click PLC Configuration—Append PLC Project, in the dialog box that pops up, select the file that was compiled in the PLC

Control interface earlier CX5120-TEST.tpy, click the OK. Expand the PLC

Configuration drop-down menu, see the following figure, it could see the input and output variables.

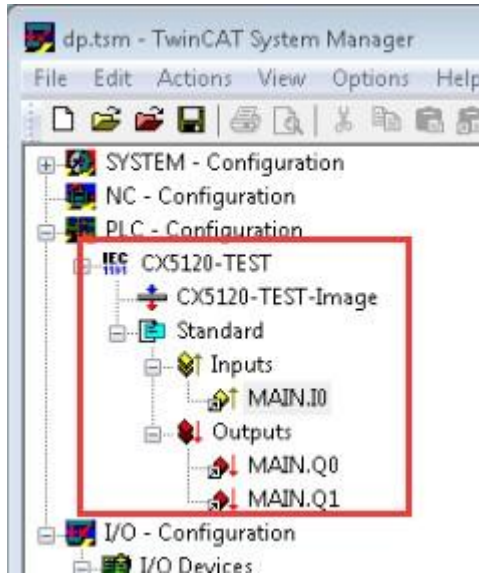

Double-click MAIN.IO, in the pop-up dialog box, could select the corresponding 485 master input address 40000.

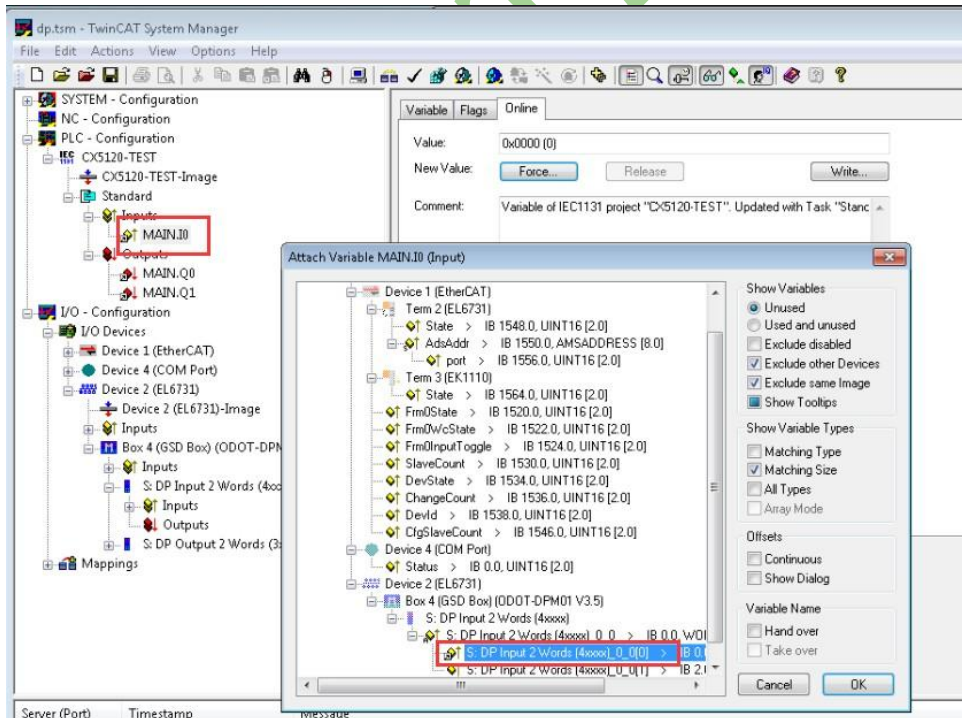

Double-click MAIN.Q0, in the pop-up dialog box, could select the corresponding 485 master output address 30000.

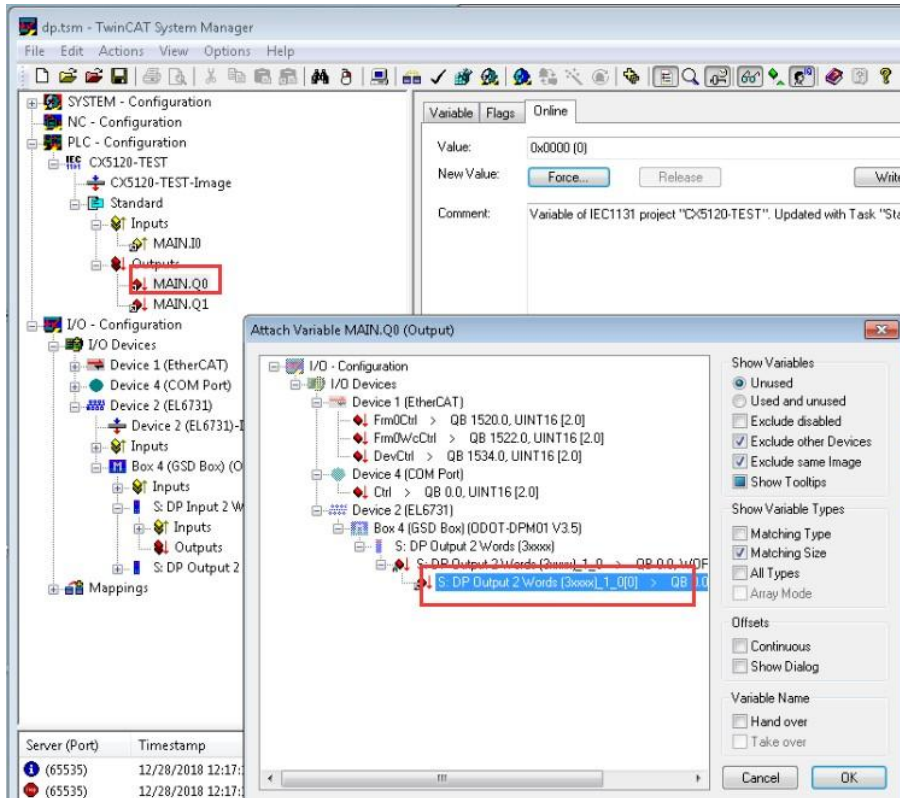

Double-click MAIN.Q1, in the pop-up dialog box, could select the corresponding 485 master output address 30001.

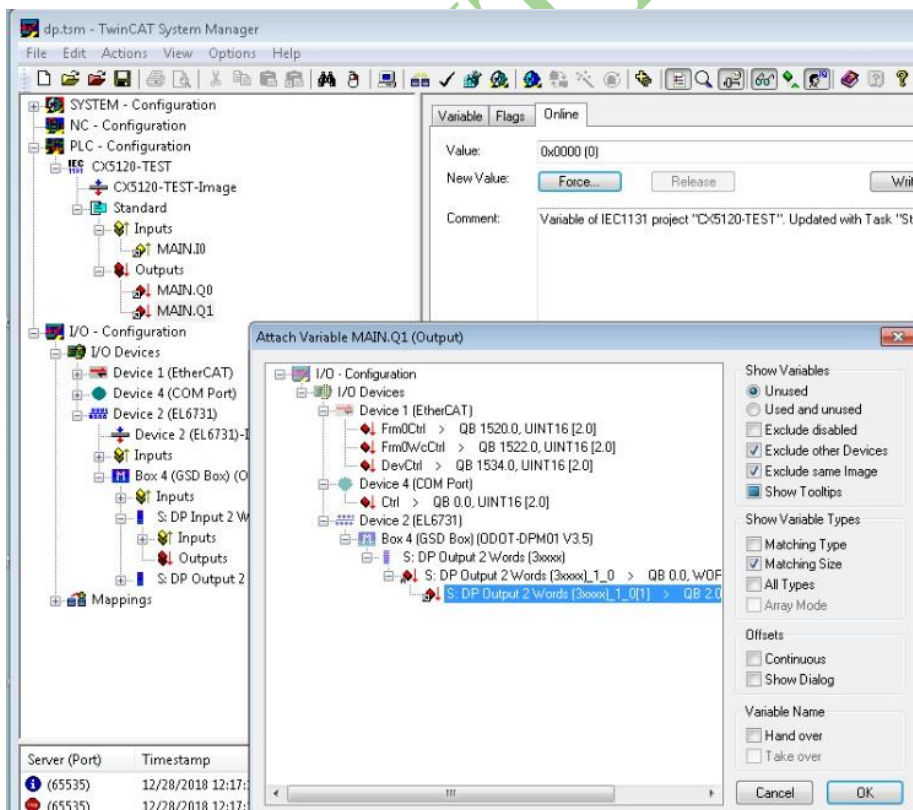

Click Active –Active Configuratin, active the configuration.

4. return the PLC Control interface, click Online—Login—Run, download the program to the CX5120, click Online—Create Bootproject to create a root program.

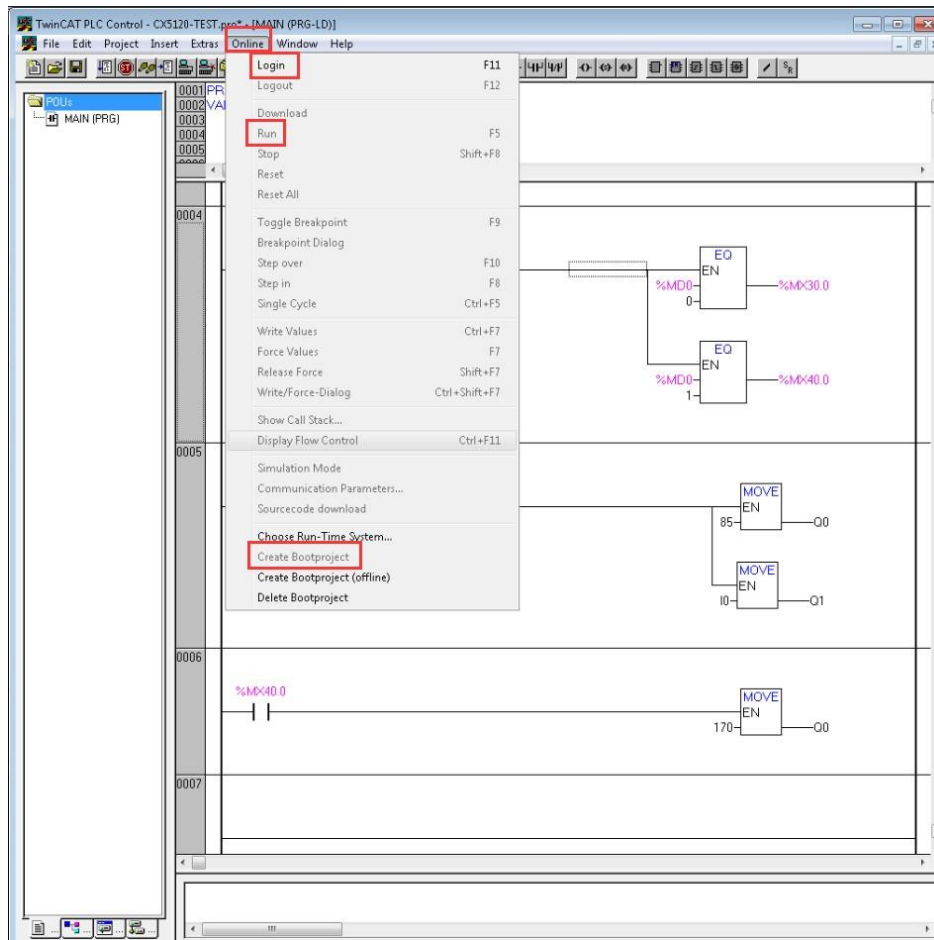

5. Return the System Manager interface, click Active –Set/Reset TwinCAT to Run Mode, at this point, DPM01 and Beckhoff's DP adapter set up DP communication. 6 、 Online monitoring, open the MODBUS POLL software, simulate the master system connected to the gateway 485. The data of the CX5120 PLC can be monitored and displayed alternately at the system address 30000 of 485 master, and the data of the 30001 changes with the data of the 40000.

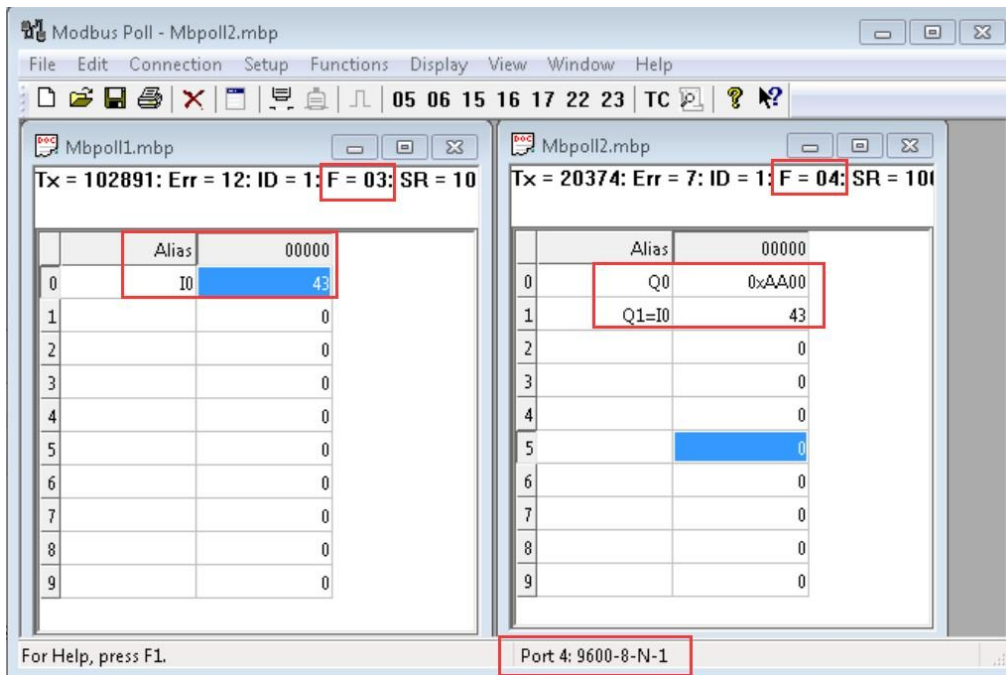

7 Annex

7.1 Modbus-RTU Protocol Introduction

For user, it is important to understand that Modbus has 8 important function codes corresponding to 4 areas: 4 read, 2 write a single bit or register, and 2 write multiple bits or multiple registers (Address description adopts PLC address).

7.1.1 Modbus Storage Area

The storage area of the controller (or Modbus device) involved in Modbus is identified by 0XXXX, 1XXXX, 3XXXX and 4XXXX.

Storage ID	Name	Data Type	Read/Write	Storage Unit Address
0XXXX	Output Coil	Bit	Read/Write	00001~0XXXX, XXXX : related to the device
1XXXX	Discrete Input	Bit	Read Only	10001~1XXXX, XXXX : related to the device

3XXXX	Input Register	Word	Read Only	30001~3XXXX, XXXX : related to the device
4XXXX	Output/Holding Registers	Word	Read/Write	40001~4XXXX, XXXX : related to the device

7.1.2 Modbus Function Code

Modbus messages are relatively fixed, so it could know the structure after reading a few messages, and users can inquire about it when necessary.

(1) Read output coil status

Function Code : 01H

Master station inquiry message format:

Address	Function Code	Start Address High Byte	Start Address Low Byte	Number of coils High Byte	Number of coils Low Byte	CRC
0x11	0x01	0x00	0x13	0x00	0x25	xxxx

Function: Read slave station output coil 0XXXX status.

Note: Some device coil start address is 00000, which corresponds to address 00001 in the device, and the sequence is postponed.

In this example: read the output coil of the slave station No. 0x11, the register start address is 0x13=19, and the number of coils is 0x0025H=37.

Therefore, the function of this query message is: read the output coil 00019-00055 of the slave station No. 0x11 (17), A total of 37 coil status.

Slave station response format:

Address	Function Code	Byte Count	Coil Status 19-26	Coil Status 27-34	Coil Status 35-42	Coil Status 43-50	Coil Status 51-55	CRC
0x11	0x01	0x05	0xCD	0x6B	0xB2	0x0E	0x1B	xxxx

Function: Slave returns to output coil 0XXXX status.

(2) Read discrete input status

Function Code: 02H

Master station query message format :

Address	Function Code	Start Address High Byte	Start Address Low Byte	Number of coils High Byte	Number of coils Low Byte	CRC
0x11	0x02	0x00	0xC4	0x00	0x16	xxxx

Function: Read the status of slave station input coil 1XXXX.

Note: Some equipment coil start address is 10000, which corresponds to the address of 10001 in the device, and the sequence is postponed.

In this example: read the input coil of the slave station No. 0x11, the starting address is 0x00C4=196, and the number of coils is 0x0016=22.

Therefore, the function of this query message is: read the input coil 10196-10217 of the slave station No. 0x11 (17), a total of 22 discrete input status.

Slave station response format:

Address	Function Code	Byte Count	DI 10196-10203	DI 10204-10211	DI 10212-10217	CRC
0x11	0x02	0x03	0xAC	0xDB	0x35	xxxx

Function: Slave returns to input coil 1 XXXX status.

(3) Read output/holding register

Function Code: 03H

Master station query message format:

Address	Function Code	Register Start Address High Byte	Register Start Address Low Byte	Number of Registers High Byte	Number of Registers Low Byte	CRC
0x11	0x03	0x00	0x6B	0x00	0x03	xxxx

Function: Read slave station holding register 4XXXX value.

Note: The starting address of some device registers is 40000, which corresponds to the address 40001 in the device, and the sequence is postponed.

In this example: read the holding register value of the slave station No. 0x11, the starting address is 0x006BH=107, and the number of registers is 0x0003.

Therefore, the function of this query message is: read the value of 3 holding registers 40107-40109 of the slave station No. 0x11 (17H).

Address	Function Code	Byte Count	Register 40107 High Byte	Register 40107 Low Byte	Register 40108 High Byte	Register 40108 Low Byte	Register 40109 High Byte	Register 40109 Low Byte	CRC
0x11	0x03	0x06	0x02	0x2B	0x01	0x06	0x2A	0x64	xxxx

Function: The slave returns to the value of the holding register: (40107)=0x022B, (40108)=0x0106, (40109)=0x2A64

(4) Read the input register

Function code: 04H

Master station query message format:

Address	Function Code	Register Start Address High Byte	Register Start Address Low Byte	Number of Registers High Byte	Number of Registers Low Byte	CRC
0x11	0x04	0x00	0x08	0x00	0x01	xxxx

Function: Read slave station input register 3XXXX value.

Note: In some devices, the register start address is 30000, which corresponds to the address 30001 in the device, and the sequence is postponed.

In this example: read the input register value of the slave station No. 0x11, the start address is 0x0008H, and the register number is 0x0001.

Therefore, the function of this query message: read the value of 1 input register 30008 of slave station No. 0x11 (17).

Slave station response format:

Address	Function Code	Byte Count	Input Register 30008 High Byte	Input Register 30008 Low Byte	CRC
0x11	0x04	0x02	0x01	0x01	xxxx

Function: The slave station returns to the value of the input register 30008; (30008)=0x0101

(5) Force a single coil

Function code: 05H

Master station query message format:

Address	Function Code	Coil Address High Byte	Coil Address Low Byte	Break Flag	Break Flag	CRC
---------	---------------	------------------------	-----------------------	------------	------------	-----

0x11	0x05	0x00	0xAC	0xFF	0x00	xxxx
------	------	------	------	------	------	------

Function: Force the 0XXXX value of slave station coil 0x01 (17). In some devices, the coil start address is 00000, which corresponds to the address 00001 in the device, and the sequence is postponed.

Break Flag = FF00, force the coil ON.

Break Flag = 0000, force the coil OFF.

Example: The starting address is 0x00AC=172. Force No. 17 slave station coil 0172 to ON status.

Response format: return to the original text

Function: Force No. 17 slave device coil 0172 ON and return to the original text

Address	Function Code	Coil Address High Byte	Coil Address Low Byte	Break Flag	Break Flag	CRC
0x11	0x05	0x00	0xAC	0xFF	0x00	xxxx

(6) Preset single holding register

Function Code: 06H

Master station query message format:

Address	Function Code	Register Start Address High Byte	Register Start Address Low Byte	Number of Registers High Byte	Number of Registers Low Byte	CRC
0x11	0x06	0x00	0x87	0x03	0x9E	xxxx

Function: Preset single holding register 4XXXX value. In some devices, the coil start address is 40000, which corresponds to the address 40001 in the device, and the sequence is postponed.

Example: Preset the value of the single holding register 40135 of No. 17 slave device to 0x039E;

Response format: return to the original text

Address	Function Code	Register Start Address High Byte	Register Start Address Low Byte	Number of Registers High Byte	Number of Registers Low Byte	CRC
0x11	0x06	0x00	0x87	0x03	0x9E	xxxx

Function: Preset the No. 17 slave device single holding register 40135 value to 0x039E and return to the original text.

(7) Force Multi-coil

Function Code: 0FH

Master station query message format:

Address	Function Code	Coil Start Address High Byte	Coil Start Address Low Byte	Number of coils High Byte	Number of coils Low Byte	Byte Count	Coil Status 20-27	Coil Status 28-29	CRC
0x11	0x0F	0x00	0x13	0x00	0x0A	0x02	0xCD	0x00	xxxx

Function: Force multiple continuous coils 0XXXX to ON/OFF status. Note: In some devices, the coil start address is 00000, which corresponds to the address 00001 in the device, and the sequence is postponed.

In this example: Force multiple continuous coils in slave station 0x11, the start address of the coil is 0x0013=19, and the number of coils is 0x000A=10.

Therefore, the function of this query message is: to force the value of 00019-00028 of the 10 coils of slave station No. 0x11 (17); CDH→00019-00026; 00H→00027-00028.

Slave station response format:

Address	Function Code	Coil Start Address High Byte	Coil Start Address Low Byte	Number of coils High Byte	Number of coils Low Byte	CRC
0x11	0x0F	0x00	0x13	0x00	0x0A	xxxx

(8) Preset multiple registers

Function Code: 10H

Master station query message format:

Address	Function Code	Start Register Address High Byte	Start Register Address Low Byte	Number of Registers High Byte	Number of Registers Low Byte	Byte Count	Data High Byte	Data Low Byte	Data High Byte	Data Low Byte	CRC

0x11	0x10	0x00	0x87	0x00	0x02	0x04	0x01	0x05	0x0A	0x10	xxxx
------	------	------	------	------	------	------	------	------	------	------	------

Function: Preset multiple holding register values 4XXXX of the slave station. Note: In some devices, the holding register start address is 40000, which corresponds to the address 40001 in the device, and the sequence is postponed.

In this example: Preset multiple holding register values of slave station 0x11, the register start address is 0x0087=135, and the number of coils is 0x0002=2. Therefore, the function of this query message is: preset the value of 2 holding registers of slave station No. 0x11 (17);

0105H→40135; 0A10H→40136.

Response Format:

Address	Function Code	Start Register Address High Byte	Start Register Address Low Byte	Number of Registers High Byte	Number of Registers Low Byte	CRC
0x11	0x10	0x00	0x87	0x00	0x02	xxxx

7.2 Brief introduction of serial port network topology

7.2.1 RS232

RS232 is one of serial communication interfaces controlled by industry. It is widely used to connect computer serial interface with peripherals. RS232 using a signal and a signal transmission form, return lines were in the land of the three wire connection mode, can realize full-duplex communications, the transmission signals for single ended, the total transmission of easy to generate common-mode interference, so the noise resistance is weak, the transmission distance is limited, RS232 interface standards stipulated in the code element distortion maximum transmission distance is less than 4% under the condition of standard values of 50 feet (15 meters) (more than 15 m long distance communication, need to adopt modem), the maximum transmission distance is also associated with communication baud rate, in the process of practical application, if the transmission distance is far, Please reduce the baud rate.

In order to reduce the electromagnetic interference from the outside during the signal transmission, please use the shielded cable as the communication cable.

RS232 interface standard specifies that TXD and RXD:

RS232 USES negative logic to transmit signals and takes the signal of $-(3\sim 15)$ V as logic "1". Take the signal of $+(3\sim 15)$ V as logical "0"; Voltages between -3 and +3V are meaningless, as are voltages lower than -15V or higher than +15V.

RS232 Interface Classification:

DB9 header interface



The top left corner is 1, the bottom right corner is 9

9-pin RS232 serial port (DB9)		
Pin	Name	Function
1	CD	Carrier detect
2	RXD	Receive data
3	TXD	Send data
4	DTR	Data terminal ready
5	GND	Signal ground
6	DSR	Data ready
7	RTS	Request to send
8	CTS	Clear to send
9	RI	Ring alert

As the RS232 interface has the above electrical characteristics, it can only realize point-to-point communication.

RS232 communication wiring diagram is shown in the figure below:

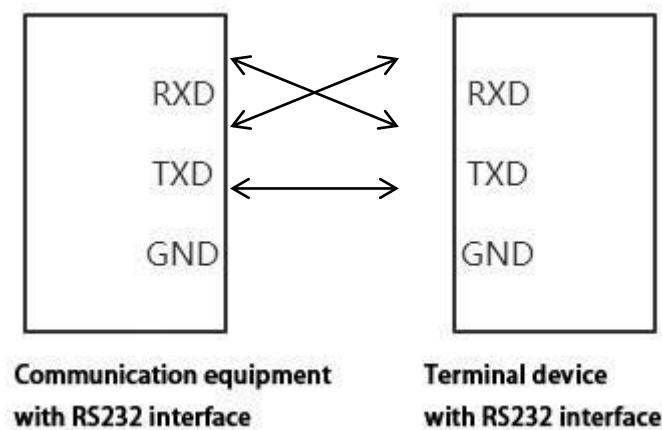

7.2.2 RS422

The full name of RS422 interface standard is "Electrical Characteristics of Balanced Voltage Digital Interface Circuit", which defines the characteristics of the interface circuit. RS422 adopts four-wire plus ground wire (T+, T-, R+, R-, GND), full-duplex, differential transmission, multi-point communication data transmission protocol. It USES a balanced transmission line that is unidirectional/non-reversible, with or without an enabling end. Because the receiver USES a high input impedance and the sending driver is stronger than RS232, it is allowed to connect multiple receiving nodes on the same transmission line, up to 10 nodes. That is, one Master device (Master), the rest are slave devices (Slave), and the slave devices cannot communicate with each other, so RS-422 supports point-to-many two-way communications. The RS-422 has a maximum transmission range of 4,000 feet and a maximum transmission rate of 10Mb/s. The length of the balanced twisted pair is inversely proportional to the transmission rate, and the maximum transmission distance can be reached only if the rate is below 100KB /s. The highest rate of transmission can be obtained only over very short distances. Generally, the maximum transmission rate obtained on 100 meters long twisted pair is only 1Mb/s.

The RS-422 requires a terminal resistance that is approximately equal to the characteristic impedance of the transmission cable. In short distance transmission, no final resistance is required, that is, no final resistance is generally required below 300 meters. The final resistance is connected to the farthest end of the transmission cable. In a master multi-slave network connection, all the sending terminals of the slave connect to the receiving terminals of the master station by daisy-chain. All the receiving ends of the slave stations are connected by daisy-chain to the sending end which is finally connected to the master station.

The RS422 pin definition:

RS422 (9 Pin)		Function	Remark
3	R-	Receive negative	Must connect
2	T-	Send negative	Must connect
7	R+	Receiving positive	Must connect
8	T+	Send positive	Must connect



The upper left corner is 1, the lower right corner is 9.

The RS422 communication wiring diagram is shown in the figure:

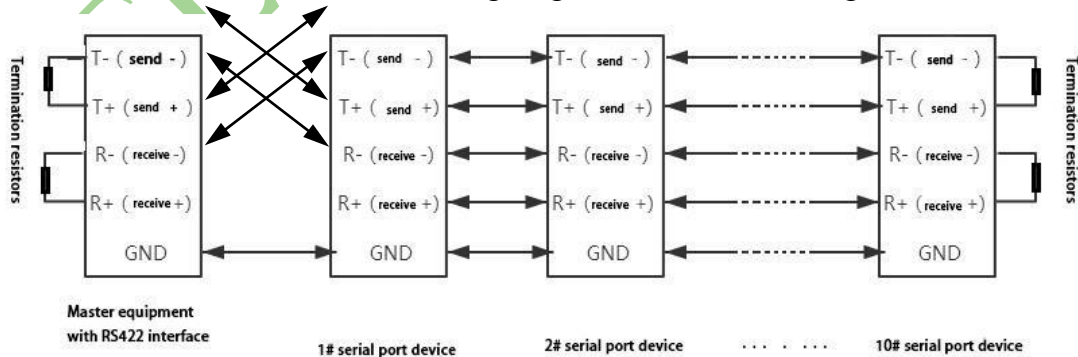

7.2.3 RS485

Since the RS-485 is developed from the RS-422, many electrical provisions of the RS-485 are similar to those of the RS-422. If they all adopt the balanced transmission mode, they all need to connect the final resistance on the transmission line, etc. The RS-485 can adopt two-wire and four-wire mode, and the two-wire system can realize real multi-point two-way communication.

RS485 is a standard for defining the electrical characteristics of drivers and receivers in a balanced digital multipoint system, using a combination of balanced drivers and differential receivers for enhanced common-mode dry resistance, i.e., good noise interference resistance. Because the semi-duplex network composed of RS485 interface generally adopts the wiring mode of two-wire system and adopts differential signal to transmit data, the voltage difference between the two lines is $-(2-6)V$ to represent logic "0", and the voltage difference between the two lines is $+(2-6)V$ to represent logic "1".

RS485 signal transmission distance is related to communication baud rate, the higher the baud rate, the shorter the transmission distance, under the condition of the baud rate is not higher than 100 KBPS, theory of the maximum communication distance is about 1200 meters, in the process of practical application, Due to electromagnetic interference and other factors, often cannot meet the maximum communication distance, if in a long-distance communication, please reduce the baud rate, to reduce the signal during transmission by external electromagnetic interference, please use twisted-pair shielded cable as a communication cable.

RS485 bus in the case of no trunk to support a maximum of 32 nodes, node and node between the "Daisy chain" connection mode, in the communication cable at both ends need to add terminal resistance, the resistance value is required to be approximately equal to the transmission cable characteristic impedance. In short distance transmission, no final resistance is required, that is, no final resistance is generally

required below 300 meters. The final resistance is connected at the ends of the transmission cable.

RS485 9 pin definition:

Pin	Name	Function	Remark
1	Data-/B-/485-	Send positive	Must connect
2	Data+/A+/485+	Receiving positive	Must connect
5	GND	Ground wire	

The RS485 communication wiring diagram is shown in the figure:

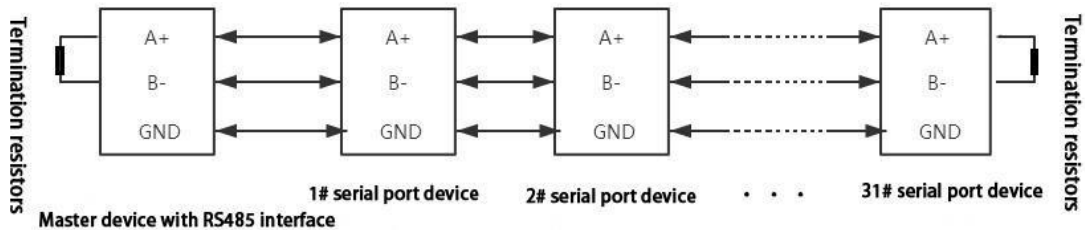

Odot Automation System Co., Ltd.

Add: Plant No. 204 MianYang Comprehensive Bonded Zone, Eastern section of FeiYun Avenue, MianYang, Sichuan Province, China. 621000

Tel: +86-0816-2538289



Zip Code: 621000

Email: sales@odotautomation.com

Web: www.odotautomation.com

FLEXYTEC.COM